

TM 11-6625-366-15

DEPARTMENT OF THE ARMY TECHNICAL MANUAL

ORGANIZATIONAL, DS, GS, AND DEPOT MAINTENANCE MANUAL

MULTIMETER TS-352B/U

(NSN 6625-00-553-0142)

This copy is a reprint which includes current pages from Changes 1 through 4.

HEADQUARTERS, DEPARTMENT OF THE ARMY

JANUARY 1967

WARNING

Be careful when making measurements while using the voltage and ammeter ranges of the multimeter. Serious injury or death may result from contact with the circuits being measured.

DON'T TAKE CHANCES!

DANGEROUS VOLTAGES EXIST AT THE 50V TO 5000V

JACKS AND CURRENT JACKS

CHANGE }
No. 4 }

HEADQUARTERS
DEPARTMENT OF THE ARMY
WASHINGTON, DC, 4 June 1980

**Organizational, Direct Support, General
Support, and Depot Maintenance Manual
MULTIMETER TS-352B/U
(NSN 6625-00-553-0142)**

TM 11-6625-366-15, 5 January 1967, is changed as follows:

1. New or changed material is indicated by a vertical bar in the margin.
2. Remove old pages and insert new pages as indicated below:

<i>Remove</i>	<i>Insert</i>
i and ii	i and ii
1-1 through 1-2.1	1-1 and 1-2
2.1 thru 2-8	None
3-1 through 3-3	3.1 through 3-3
6-1 and 6-2	6-1 and 6-2
6-11	6-11/6-12(blank)
7-1	7-1/7-2(blank)
A-1	A-1/A-2(blank)

3. Insert this sheet in the front of the manual for record purposes.

TM 11-6625-366-15

By Order of the Secretary of the Army:

E. C. MEYER
General, United States Army
Chief of Staff

Official:

J. C. PENNINGTON
Major General, United States Army
The Adjutant General

Distribution:

Active Army

	Units org under fol TOE:					
HISA (Ft Monmouth) (21)						
USAINSCOM(2)	1-127 (1)	6-166 (1)	8-510 (1)	11-303 (1)	29-119 (1)	55-117 (1)
COE (1)	1-137 (1)	6-175 (1)	8-565 (1)	11-327 (1)	29-127 (1)	55-118 (1)
TSG (1)	1-165 (1)	6-176 (1)	9-22 (1)	11-347 (1)	29-134 (1)	55-157 (1)
USAARENBD (1)	1-166 (1)	6-185 (1)	9-117 (1)	11-357 (1)	29-136 (1)	55-225 (1)
DARCOM (1)	1-252 (1)	6-186 (1)	10-202 (1)	11-367 (1)	29-137 (1)	55-227 (1)
TRADOC (1)	3-267 (1)	6-200 (1)	10-206 (1)	11-368 (1)	29-139 (1)	55-247 (1)
OS Maj Comd (4)	5-25 (1)	6-201 (1)	10-207 (1)	11-377 (1)	29-207 (2)	55-248 (1)
TECOM (2)	5-26 (1)	6-300 (1)	10-407 (1)	11-500 (AA-AC)	29-227 (1)	55-405 (1)
USACC (4)	5-35 (1)	6-302 (1)	10-417 (1)	17 (1)	29-245 (1)	55-406 (1)
MDW (1)	5-36 (1)	6-356 (1)	11-15 (1)	17-95 (1)	29-247 (1)	55-407 (1)
Armies (2)	5-37 (1)	6-365 (1)	11-16 (1)	17-96 (1)	29-427 (1)	55-457 (1)
Corps (2)	5-52 (1)	6-366 (1)	11-17 (1)	17-100 (1)	29-512 (1)	55-458 (1)
USACC-CONUS (2)	5-78 (1)	6-405 (1)	11-18 (1)	29-1 (1)	29-550 (1)	57 (1)
USACC-A (2)	5-101 (1)	6-406 (1)	11-19 (1)	29-11 (1)	29-610 (2)	57-100 (1)
USACC-EUR (2)	5-107 (1)	6-425 (1)	11-25 (1)	29-15 (1)	30-25 (1)	57-102 (1)
USACC-PAC (2)	5-111 (1)	6-426 (1)	11-27 (1)	29-16 (1)	30-28 (1)	67 (1)
USACC-SO (2)	5-112 (1)	6-455 (1)	11-35 (1)	29-17 (1)	30-34 (1)	77-100 (1)
Svc Colleges (1)	5-115 (1)	6-456 (1)	11-36 (1)	29-21 (1)	31-105 (1)	77-102 (1)
USASIGS (5)	5-116 (1)	6-502 (1)	11-37 (1)	29-25 (1)	32-52 (1)	
USAADS (2)	5-117 (1)	6-555 (1)	11-38 (1)	29-26 (1)	32-56 (1)	
USAFAS (2)	5-127 (1)	6-556 (1)	11-39 (1)	29-27 (1)	32-57 (1)	
USAARMS (2)	5-137 (1)	6-557 (1)	11-45 (1)	29-35 (1)	32-78 (1)	
USAIS (2)	5-145 (1)	6-575 (1)	11-46 (1)	29-36 (1)	32-500 (1)	
USAES (2)	5-146 (1)	6-576 (1)	11-85 (1)	29-37 (1)	37 (1)	
USAICS (3)	5-155 (1)	6-577 (1)	11-86 (1)	29-41 (1)	44-2 (1)	
MAAG (1)	5-156 (1)	6-615 (1)	11-87 (1)	29-42 (1)	44-12 (1)	
USARMIS (1)	5-177 (1)	6-616 (1)	11-97 (1)	29-51 (1)	44-85 (1)	
USAERDAA (1)	5-195 (1)	6-617 (1)	11-98 (1)	29-55 (1)	44-86 (1)	
USAERDAW (1)	5-196 (1)	6-619 (1)	11-116 (1)	29-56 (1)	44-87 (1)	
USAJFKCENMA (2)	5-197 (1)	6-700 (1)	11-117 (1)	29-75 (1)	44-235 (1)	
VFGH (2)	5-198 (1)	6-701 (1)	11-127 (1)	29-79 (1)	44-236 (1)	
Ft Gordon (19)	5-201 (1)	6-702 (1)	11-137 (1)	29-85 (1)	44-237 (1)	
Ft Carson (5)	5-305 (1)	7 (1)	11-147 (1)	29-86 (1)	44-535 (1)	
Army Dep (1) except	5-306 (1)	7-45 (1)	11-205 (1)	29-87 (1)	44-537 (1)	
SAAD (39)	5-327 (1)	7-46 (1)	11-206 (1)	29-97 (1)	44-57 (1)	
TOAD (14)	5-500 (1)	7-100 (1)	11-215 (1)	29-102 (1)	54-042 (1)	
SHAD (2)	6-100 (1)	8-26 (1)	11-216 (1)	29-105 (1)	55-2 (1)	
Ft Gillem (19)	6-115 (1)	8-25 (1)	11-217 (1)	29-107 (1)	55-11 (1)	
USA Dep (1)	6-116 (1)	8-27 (1)	11-218 (1)	29-109 (1)	55-27 (1)	
Sig Sec USA Dep (1)	6-155 (1)	8-137 (1)	11-225 (1)	29-111 (1)	55-89 (1)	
Ft Richardson (CERCOM Ofc) (2)	6-156 (1)	8-187 (1)	11-226 (1)	29-112 (1)	55-99 (1)	
	6-165 (1)	8-197 (1)	11-302 (1)	29-118 (1)	55-111 (1)	

NG: State AG (3): Units — Same as Active Army.

USAR: None

For explanation of abbreviations used see AR 310-50.

CHANGE }
No. 3 }

HEADQUARTERS
DEPARTMENT OF THE ARMY
WASHINGTON, D. C., 28 May 1974

**Operator's, Organizational, DS, GS,
and Depot Maintenance Manual**

MULTIMETER TS-352B/U

TM 11-6625-366-15, 5 January 1967, is changed as follows:

1. A vertical bar appears opposite changed material.
2. Remove and insert pages as indicated in the page list below:

<i>Remove</i>	<i>Insert</i>
i and ii	i and ii
1-1 and 1-21-1 through 1-2.1
B-1 through B-3	none

3. File this change sheet in front of the publication for reference purposes.

By Order of the Secretary of the Army:

CREIGHTON W. ABRAMS
General, United States Army
Chief of Staff

Official:

VERNE L. BOWERS
Major General, United States Army
The Adjutant General

Distribution:

Active Army:

USASA (2)
CNGB (1)
ACSC-E (2)
Dir of Trans (1)
COE (1)
TSG (1)
USAARENBD (1)
USAMB (10)
AMC (1)
TRADOC (2)
ARADCOM (2)
ARADCOM Rgn (2)
OS Maj Cored (4)
LOGCOMDS (3)
MICOM (2)
TECOM (2)
USACC-CONUS (2)
USACC-A(2)
USACC-EUR (2)
USACC-PAC (2)
USACC-SO (2)
USACC Fac (1)
USASTRATCOM-T (2)
USACC (4)
MDW (1)
Armies (2)
Corps (2)
HISA Ft Monmouth (18)
Svc Colleges (1)
USASESS (5)
USAADS (2)
USAFAS (2)

USAARMS (2)
USAIS (2)
USAES (2)
USAINTCS (3)
WRAMC (1)
ATS (1)
USAMFSS (2)
USAJFKCENMA (2)
VFGH (2)
FGH (2)
AV Comm Cen (1)
Fort. Gordon (10)
Fort Huachuca (10)
WSMR (1)
Fort Carson (5)
Ft Richardson (ECOM OFc) (2)
Army Dep (1) except
LBAD (14)
SAAD (30)
TOAD (14)
ATAD (10)
USA Dep (2)
Sig Sec USA Dep (2)
Sig Dep (2)
Sig FLDMS (1)
USAERDAW (1)
MAAG (1)
USARMIS (1)
Div (1)
Bde (1)
Bn (1)
Co (1)

NG: State AG (3); Units-Same as Active Army.

USAR: None

For explanation of abbreviations used, see AR 310-50.

Change }
No. 2 }

HEADQUARTERS
DEPARTMENT OF THE ARMY
WASHINGTON, D.C., 5 January 1971

Operator's, Organizational, DS, GS, and Depot Maintenance Manual

MULTIMETER TS-352B/U

TM 11-6625-366-15,5 January 1967, is changed as follows:

1. The title of the manual is changed as shown above.
2. Remove and insert pages as indicated in the page list below.

<i>Remove</i>	<i>Insert</i>
i through 1-2	i through 1-2
6-7 through 6-9	6-7 through 6-9
6-11	6-11
A-1	A-1

3. File this change sheet in front of the publication for reference purposes.

By Order of the Secretary of the Army:

Official:
KENNETH G. WICKHAM,
Major General, United States Army.
The Adjutant General.

W. C. WESTMORELAND,
General, United States Army,
Chief of Staff.

Distribution:

Active Army:

USASA(10)
CNGB (1)
ACSC-E (2)
Dir of Trans(1)
CofEngrs(1)
CofSpts(1)
TSg (1)
USAARENBD(2)
USAMB(10)
UJSAMC1)
USAMICOM(4)
USASTRATCOM(4)
USATECOM(2)
USAESC (70)
USACDC(2)
USACDC Agcy(1)
USACDEC(10)
CONARC(5)
ARADCOM(2)
ARADCOMRgn(2)
OS Maj Comd (4)
LOGCOMD(5)
USASTRATCOM-CONUS(10)
USASTRATCOM-EUR(10)
USASTRATCOM-PAC(10)
USASTRATCOM-A(5)
USASTRATCOM-SO(5)
USASTRATCOM-SIG G-PT
MDW(1)
Armies(2)
Div(2)except
1st Cav Div (3)
Corps (2)
Div Arty(2)
Corps Arty(2)
Bde(2)
Regt/Gp/bat gp(2)
Bn(2)
Co 2)
Det(2)
USASCS(10)

Instl (2) except
Ft Gordon(10)
Ft Huachuca (10)
F t Carson (25)
WSMR(3)
Sve Colleges (2)
USASESS(10)
USAADS(2)
USAFAS(5)
USAARMS(2)
USAIS(5)
USAES(5)
USAINTS(3)
MESS(5)
USATC FA(5)
Gen Dep(2)
Sig Sec, Gen dep(5)
Sig Dep(2)
Army Dep (2) except
SAAD(30)
LBAD(14)
TOAD(14)
ATAD(10)
LEAD(7)
NAAD(5)
SVAD(5)
USAERDAA(2)
USAERDAW(5)
USACRREL(2)
MAAG(1)
USARMIS(1)
ATS(1)
VFGH(5)
FGH(5)
AV Comm Cen(1)
USASA Fld Sta(1)
USASTRATCOM Fac(1)
Sig FLDMS(2)
WRAMC(2)
USAJFKCENMA(5)

ARNG: State AC (3); Units—Same as Active Armyexcept allowance is one (1) copy each.

USAR: None.

Organizational, DS, GS, and Depot Maintenance Manual
MULTIMETER TS—352B/U

CHANGE
No. 1

HEADQUARTERS,
DEPARTMENT OF THE ARMY
WASHINGTON, D. C., 24 July 1967

TM 11-6625-366-15, 5 January 1967, is changed as follows:

1. Remove and insert pages as indicated below.

Remove pages	Insert pages
1-1 and 1-2	1-1, 1-2, 1-2.1
6-7	6-7
6-9 and 6-10	6-9 and 6-10
Page following 6-10 (paragraph 6-10).	Page following 6-10 (paragraph 6-10).
6-11	6-11

2. Retain this transmittal sheet in the front of the manual for future reference.

By Order of the Secretary of the Army:

HAROLD K. JOHNSON,
General, United States Army,
Chief of Staff.

Official:

KENNETH G. WICKHAM,
Major General, United States Army,
The Adjutant General.

Distribution:

Active Army:

CNGB (1)
CC-E (7)
Dir of Trans (1)
CofEngrs (1)
TSG (1)
Cof SptS (1)
USAARENBD (2)
USAIB (5)
USA Arty Bd (2)
USACDCEA (1)
USACDCCBRA (1)
USACDCCEA (1)
USACDCCEA (Ft Huachuca) (1)
USADCOA (1)
USACDCQMA (1)
USACDCTA (1)
USACDCADA (1)
USACDCARMA (1)
USACDCAVNA (1)
USACDCARTYA (1)
USACDCSWA (1)

USCONARC (5)
USAMC (5)
USASA (2)
USAMICOM (4)
USASTRATCOM (4)
USAESC (70)
USACDCEC (10)
ARADCOM (5)
ARADCOM Rqn (2)
OS Maj Comd (4) except
 USARJ (5)
 USARYIS (5)
LOGCOMD (2)
MDW (1)
Armies (2)
Corps (2)
USAC (3)
Div (2)
Div Arty (2)
Bde (2)
507th USASA Gp (5)
508th USASA Gp (5)
318th USASA Bn (5)

319th USASA Bn (5)
 75th USASA Co (5)
 1st USASA Fld Sta (5)
 2nd USASA Fld Sta (5)
 3rd USASA Fld Sta (5)
 4th USASA Fld Sta (5)
 5th USASA Fld Sta (5)
 6th USASA Fld Sta (5)
 8th USASA Fld Sta (5)
 9th USASA Fld Sta (5)
 12th USASA Fld Sta (5)
 13th USASA Fld Sta (5)
 14th USASA Fld Sta (5)
 15th USASA Fld Sta (5)
 Instl (2) except
 Ft Hancock (4)
 Ft Gordon (10)
 Ft Huachuca (10)
 Ft Carson (25)
 Ft Knox (12)
 WSMR (5)
 Army Dep (2) except
 LBAD (14)
 SAAD (30)
 TOAD (14)
 LEAD (7)
 SHAD (3)
 NAAD (5)
 SVAD (5)
 CHAD (3)
 ATAD (10)
 ERAD (5)
 PUAD (5)
 UMAD (5)
 SCAD (5)
 Gen Dep (2)
 Sig Sec, Gen Dep (5)
 Sig Dep (12)
 USMA (2)
 Svc Colleges (2)
 USASCS (20)
 USASESCS (5)
 USAADS (2)
 USAAMS (2)
 USAARMS (2)
 USAIS (2)
 USAES (2)
 MFSS (2)
 USACMLCS (2)
 USAOC&S (2)
 USATC Armor (2)
 USATC Engr (2)
 USATC Inf (2)
 USASTC (2)
 WRAMC (1)
 Army Pic Cen (2)
 USAJFKCENSPWAR (10)
 Sig FLDMS (2)
 AMS (1)
 USAERDAA (2)

USAERDAW (13)
 USACRREL (2)
 APG (5)
 USAEPG (5)
 USARDL (5)
 Redstone Arsenal (5)
 USARMIS: El Ealvador (5)
 Honduras (5)
 Peru (5)
 Paraguay (5)
 Ecuador (5)
 JUSMMAT (2)
 USMTMSA (2)
 ARMISH (2)
 GENMISH (2)
 MAAG: Iran (2)
 Korea (2)
 Thailand (2)
 Pakistan (2)
 Units org under fol TOE:
 (2 copies each)
 1-58
 1-100
 1-101
 1-102
 1-127
 1-128
 1-137
 1-145
 1-146
 1-147
 1-148
 1-155
 1-156
 1-157
 1-158
 1-165
 1-166
 1-167
 1-307
 5-25
 5-26
 5-48
 5-52
 5-112
 5-115
 5-118
 5-127
 5-137
 5-145
 5-146
 5-155
 5-156
 5-279
 5-348
 5-500(MC)
 6-134
 6-155
 6-166
 6-175

6-185	11-247
6-186	11-302
6-201	11-327
6-215	11-347
6-216	11-357
6-345	11-500 (AA-TK)
6-346	11-587
6-355	11-592
6-365	11-597
6-385	19-55
6-386	19-56
6-405	19-57
6-406	19-500 (OA,OC,PT)
6-425	29-1
6-246	29-11
6-455	29-15
6-456	29-16
6-555	29-17
6-556	29-21
6-557	29-25
6-565	29-35
6-575	29-36
6-576	29-37
6-577	29-41
6-615	29-51
6-616	29-55
6-617	29-56
6-619	29-57
6-700	29-75
6-701	29-79
6-702	29-85
7-45	29-86
8-500 (RA)	29-87
9-7	29-97
9-9	29-105
9-22	29-109
9-86	29-500 (GF)
9-117	30-25
9-357	30-28
9-510	32-77
11-17	32-78
11-57	32-500
11-86	44-85
11-87	44-86
11-97	44-87
11-98	44-112
11-105	44-235
11-106	44-236
11-117	44-237
11-127	44-535
11-137	44-536
11-147	44-537
11-155	44-568
11-156	55-27
11-157	55-50
11-158	55-89
11-215	55-99
11-216	55-137
11-225	55-157
11-226	55-405

55-407
55-417
55-457

55-458
55-500 (IF)

NG: State AG (3) ; units — same as Active Army except allowance is one copy to each unit.
USAR: None.
For explanation of abbreviations used, see AR 320-50.

TECHNICAL MANUAL }
No. 11-6626-366-15 }

HEADQUARTERS
DEPARTMENT OF THE ARMY
WASHINGTON, D. C., 5 January 1967

**ORGANIZATIONAL DIRECT SUPPORT, GENERAL
SUPPORT, AND DEPOT MAINTENANCE MANUAL
MULTI METER TS-352B/U
(NSN 6625-00-553-0142)**

	Paragraph	Page
CHAPTER. INTRODUCTION		
SECTION I. General	1-1-1-3.2	1-1
II. Description and data	1-4-1-8	1-1
CHAPTER 2. Deleted		
CHAPTER 3. ORGANIZATIONAL MAINTENANCE	3-1-3-8	3-1
4. FUNCTIONING OF MULTIMETER TS-352B/U	4-1-4-6	4-1
5. GENERAL SUPPORT MAINTENANCE		
SECTION I. Troubleshooting	5-1-5-4	5-1
II. Alignment	5-5-5-6	5-4
CHAPTER 6. GENERAL SUPPORT TESTING PROCEDURES	6-1-6-11	6-1
7. DEPOT OVERHAUL STANDARDS	7-1-7-4	7-1
8. SHIPMENT AND LIMITED STORAGE AND DEMOLITION TO PREVENT ENEMY USE	8-1-8-3	8-1
APPENDIX A. REFERENCES		A-1
B. Deleted		
C. MAINTENANCE ALLOCATION		C-1
INDEX		I-1

*This manual supersedes TM 11-5527, 24 October 1956, including C3, 25 June 1959, C6, 27 August 1963, and C7, 31 March 1964.

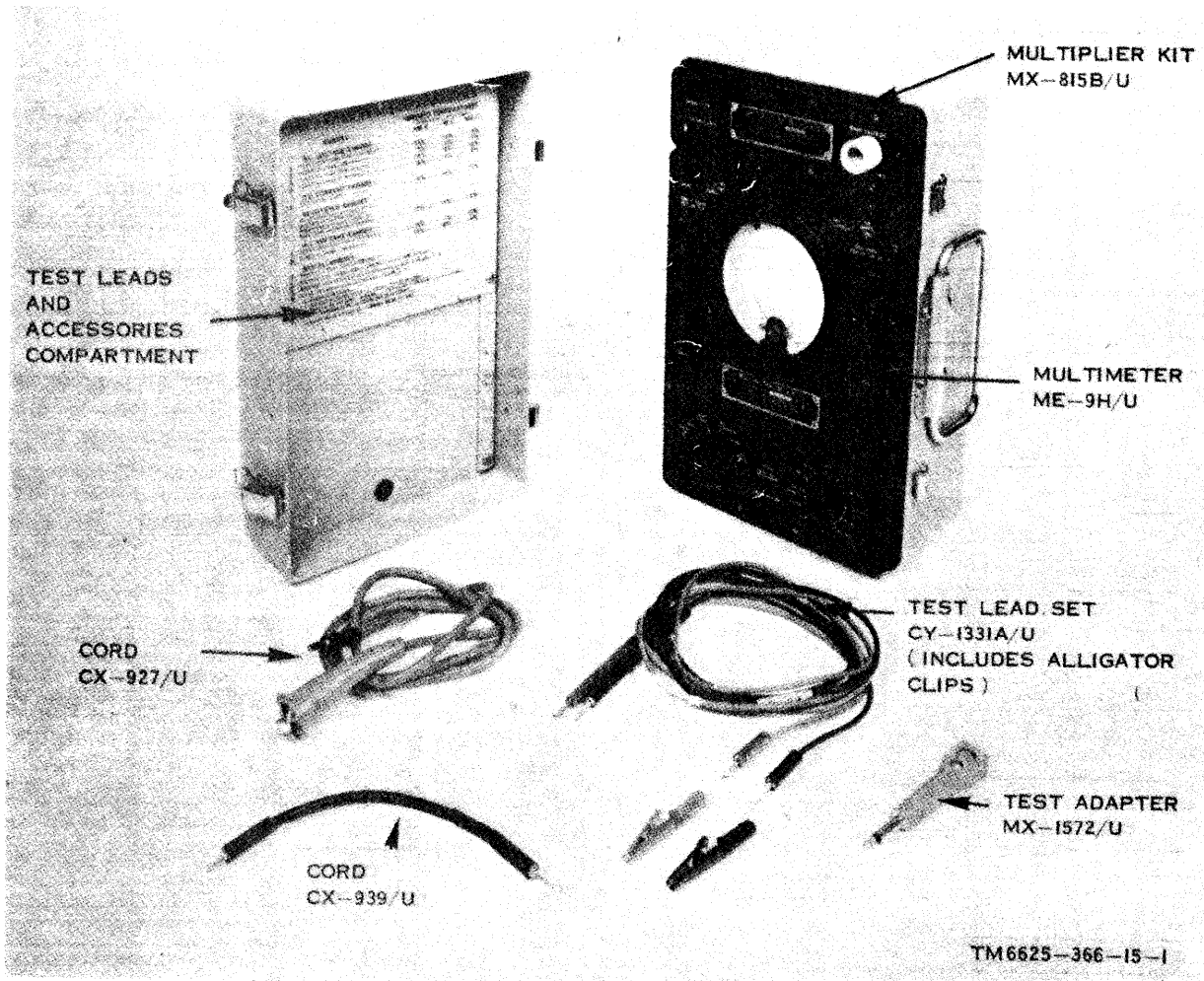

Figure 1-1. Multimeter TS-352B/U.

**CHAPTER 1
INTRODUCTION**

Section I. GENERAL

1-1. Scope

This manual contains instructions for organizational, direct support, general support, and depot maintenance of Multimeter TS-352B/U. Operating and operator's maintenance instructions are contained in TM 11-6625-366-10.

(SF 361). Fill out and forward Discrepancy in Shipment Report (DISREP) (SF 361) as prescribed in AR 55-38/NAVSUPINST 4610.33B/AFR 75-18/MCO P4610.19C and DLAR 4500.15.

1-2. Indexes of Publications

a. DA Pam 310-4. Refer to the latest issue of DA Pam 310-4 to determine whether there are new editions, changes, or additional publications pertaining to the equipment.

b. DA Pam 310-7. Refer to DA Pam 310-7 to determine whether there are modification work orders (MWO'S) pertaining to the equipment.

1-3.1 Reporting of Errors

You can help improve this manual. If you find any mistakes, or if you know of a way to improve the procedures, please let us know. Mail your letter or DA Form 2028 (Recommended Changes to Publications and Blank Forms) direct to Commander, US Army Communications and Electronics Materiel Readiness Command, ATTN: DRSEL-ME-MQ, Fort Monmouth, NJ 07703. A reply will be sent directly to you.

1-3. Maintenance Forms, Records, and Reports

a. Reports of Maintenance and Unsatisfactory Equipment. Department of the Army forms and procedures used for equipment maintenance will be those prescribed by TM 38-750, The Army Maintenance Management System.

b. Report of Packaging and Handling Deficiencies. Fill out and forward DD Form 6 (Packaging Improvement Report) as prescribed in AR 735-II-2/NAVSUPINST 4440.127 E/AFR 400-54/MC04430.3E and DSAR 4140.55.

c. Discrepancy in Shipment Report (D ISREP)

1-3.2 Reporting Equipment Improvement Recommendations (EIR)

If your Multimeter TS-352B/U needs improvement, let us know. Send us an EIR. You, the user, are the only one who can tell us what you don't like about your equipment. Let us know why you don't like the design. Tell us why a procedure is hard to perform. Put it on an SF 368 (Quality Deficiency Report). Mail it to Commander, US Army Communications and Electronics Materiel Readiness Command, ATTN: DRSEL-ME-MQ, Fort Monmouth, NJ 07703. We'll send you a reply.

Section II. DESCRIPTION AND DATA

1-4. Purpose and Use

The TS-352B/U is to measure alternating current (at) voltage and direct current (DC) voltage; direct current in amperes, milliamperes, and microampere; and resistance in ohms. Multip-

lier Kit MX-815B/U, part of the TS-352BNJ, extends the range of the equipment to allow the measurement of higher dc voltages.

1-5. Technical Characteristics

Type	Multirange instrument using a 50-microampere dc, D'Arsonval-type meter. Rectification is used for ac voltage measurements.
Frequency range	25 cycles to 5 kilocycles; useful to 20 kilocycles with a reduction in sensitivity.
Frequency error	±3 percent at 10 kilocycles; ±7 percent at 20 kilocycles.
Usable temperature range	-40° F to +131° F.

TM 11-6625-366-15

Meter sensitivity 1,000 ohms per volt for ac ranges; 1,000 or 20,000 ohms per volt for dc ranges.

Accuracy:

Dc range:

- 0 to 1,000 volts and dc current
(1,000 ohms per volt±6 percent at -40° F; ±3 percent at 77° F; ± 5percent at 131°F.
- 0 to 1,000 volts (20,000 ohms per
volt)±8 percent at -40° F;±4percent at 77° F;±6percent at 131° F.
- 0 to 5,000 volts (20,000 ohms per
volt) ±9 percent at -40°F; ±6 percent at 77°; ±8 percent at 131°F.

AC range:

- 0 to 500 volts (1,000 ohms per volt) ±7 percent at -40°F; ±4 percent at 77°F; ±5 percent at 131°F.
- 0 to 1,000 volts (1,000 ohms per
volt)±8 percent at -40 F; ±5 percent at 77° F; ±6 percent at 131° F.

Resistance ranges ±6 percent at -40° F; ±3 percent at 77°F; ±5 percent at 131° F. (Percent values are in terms of meter are length, not of ohms indicated by meter pointer.)

Meter ranges:

- Dc voltmeter 0 to 2.5, 10, 50, 250, 500, and 1,000 volts at 1,000 or 20,000 ohms per volt
0 to 5,000 volts at 20,000 ohms only.
- Ac voltmeter 0 to 2.5, 10, 50, 250,500, and 1,000 volts at 1,000 ohms per volt only.
- Resistance 0 to 1,000, 10,000, 100,000 and 10,000,00 ohms.
- Direct current0 to 250 microampere; 2.5,10,50,100, and 500 milliamperes; 2.5 and 10 amperes.
- Power supply Supplied by batteries for ohmmeter operation (1.5 and 13.5 volts).

1-6. Deleted

1-7. Description of Multimeter TS-352B/U (fig. 1-1)

a. The TS-352B/U, a volt ohm millimeter that uses self-contained batteries, is contained in a metal, immersionproof carrying case.

b. The chart below lists the nomenclature and common names of the equipment covered in this manual.

<i>Nomenclature</i>	<i>Common name</i>
Multimeter TS-352B/U	Multimeter set

<i>Nomenclature</i>	<i>Common name</i>
Multimeter ME-9H/U	Multimeter
Multiplier Kit MX-815B/U	Multiplier

1-8. Additional Equipment Required

Three Batteries BA-31 and one Battery BA-30 are required, but not furnished, to supply power to Multimeter TS-352B/U.

supply power to Multimeter TS-352B/U. The operator is required to install the batteries in the battery compartment. For battery installation instructions, refer to paragraph 2-3.

NOTE

Dry batteries are supplied in accordance with SB 11-6.

INSTALLATION AND OPERATING INSTRUCTIONS

Section I. SERVICE UPON RECEIPT OF EQUIPMENT

2-1. Unpacking

(fig. 2-1)

a. *Packaging Data.* The approximate dimensions, weight, and volume of a multimeter set, packed and unpacked, follow:

	Dimensions (in.)			Volume (cu ft)	Weight (lb)
	Height	Width	Depth		
Unpacked	11 $\frac{3}{8}$	8 $\frac{1}{4}$	6	.325	13.7
Packed	15	10	8 $\frac{1}{2}$.734	23

*b. Unpacking.**(1) Domestic packaging.*

- (a) Slit the seam along the cover of the outer corrugated carton. Fold back the cover flaps, and open the moisture-vaporproof barrier.
- (b) Slit the top seam of the water-resistant, inner corrugated carton, and open it.
- (c) Remove the technical manuals.
- (d) Remove the multimeter set from the package.

(2) Export packaging.

- (a) Cut and fold back the metal straps.
- (b) With a nailpuller, remove the nails from the wooden cover of the wooden packing case. Do not attempt to pry off the wooden cover; the equipment may become damaged.
- (c) Open the moistureproof barrier and expose the outer corrugated carton.
- (d) Proceed as described in (1) above.

2-2. Checking Unpacked Equipment

a. Inspect the equipment for damage incurred during shipment. If the equipment has

been damaged, report the damage on DD Form 6 (para 1-3b).

b. See that the equipment is complete, as listed on the packing slip. If a packing slip is not available, check the equipment against the basic issue items list (app B). Report all discrepancies in accordance with TM 38-750 (para 2-3a). Shortage of a minor assembly of part that does not affect proper functioning of the equipment should not prevent use of the equipment.

c. If the equipment has been used or reconditioned, see whether it has been changed by a modification work order (MWO). If the equipment has been modified, the MWO number will appear on the front panel near the nomenclature plate. If modified, see that any operational instruction changes resulting from the modification have been entered in the equipment manual.

Note. Current MWO'S applicable to the equipment are listed in DA Pam 310-4,

2-3. Battery Installation

(fig. 2-2)

a. To install the batteries in the multimeter, place the multimeter face down on a flat firm surface and proceed as follows:

- (1) Loosen the two retaining screws that hold the cover in place by turning the screws in a counterclockwise direction.
- (2) Lift up and remove the cover. Place the cover so that the connection diagram on the inside of the cover can be easily referred to in order to make the necessary connections.

b. Connect three Batteries BA-31 in series; use the connectors supplied. Install the bat-

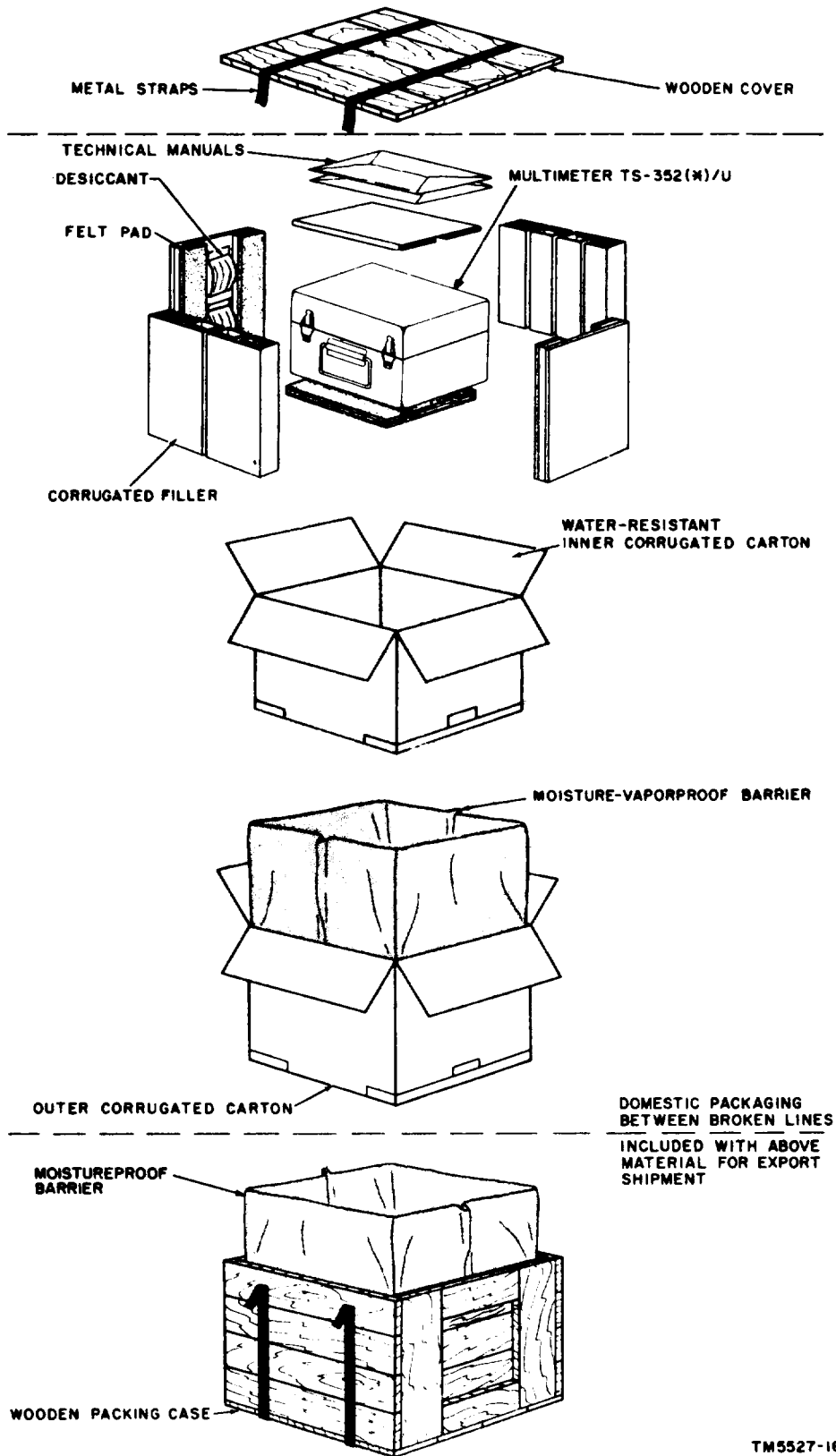

TM5527-16

Figure 2-1. Packaging diagram.

teries in the battery compartment, as indicated by the connection diagram on the battery compartment cover.

c. Place Battery BA-30 in the compartment provided so the spring makes contact with the bottom of the battery.

Note. Batteries are not furnished with the TS-352B/U.

d. Place the battery compartment cover on the bottom of the multimeter.

(1) Align the two screws with their proper holes.

(2) Hold the cover to prevent it from shifting, and secure the cover in position by turning the screws with a suitable screwdriver in a clockwise direction until tight.

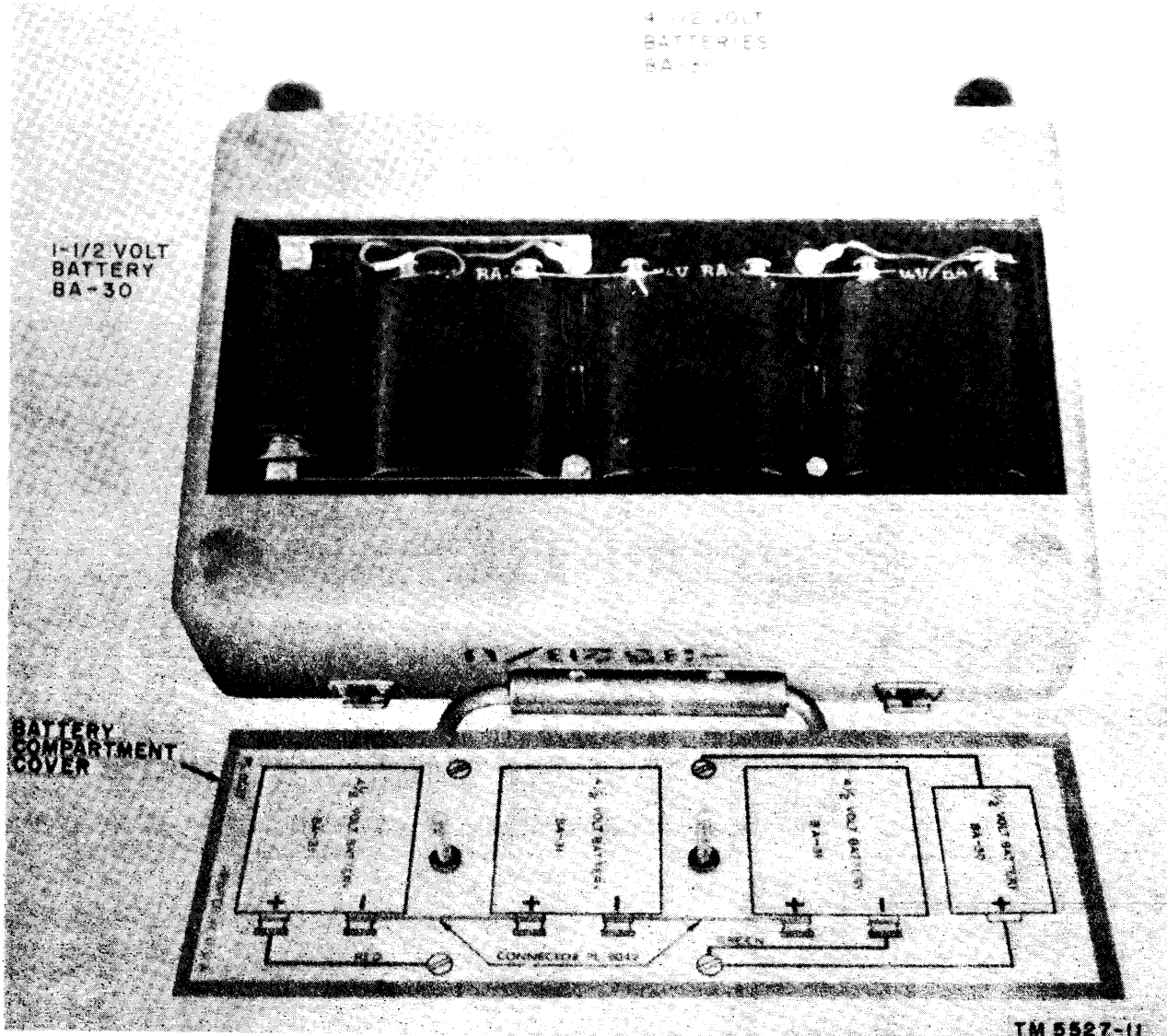

Figure 2-2. Battery compartment with batteries in position.

Section II. OPERATOR'S CONTROLS, METER, AND CONNECTORS

2-4. Damage From Improper Settings

Hazardous operation or improper setting of the controls can damage the multimeter set; therefore, knowledge of the function of the meter, controls, and connectors before operating the multimeter set is important. Refer to paragraph 2-5.

2-5. Controls, Meter, and Connectors

The following chart lists the controls, meter, and connectors of the multimeter set and indicates their functions:

Item	Function
FUNCTION switch	Used to select the type of multimeter operation desired.
Range switch- - - - -	Used to select one of the dc current or resistance ranges.
OHMS ZERO ADJ. knob.	Used to adjust the meter pointer to zero on the ohms scale.
Meter- - - - -	Indicates the value of voltage, resistance, or current measure.

Item	Function
OHMS-DC±AC jack.. ..	Common jack for all functions.
OHMS jack - - - - -	Test lead connection for measuring resistance.
+DC CURRENT jack. . . .	Red test lead connection for measuring direct current to 2.5 amperes.
+10 AMPS ONLY jack.. . .	Red test lead connection for measuring direct current to 10 amperes.
20000 OHMS PER VOLT DC jacks.	Red test lead connections measuring dc voltages (20,000 ohms-per-volt function only).
1000 OHMS PER VOLT AC DC jacks.	Red test lead connections for measuring dc or ac voltages (1,000 ohms-per-volt function only).
CONNECT TO 2.5 VOLT JACK.	Patch cord connection between the multiplier and the 2.5V jack.
5000 VOLTS DC 2000 OHMS/VOLT jack.	High voltage test lead connection to multiplier.
CASE GROUND jack- - -	Ground lead connection between multimeter case and chassis of equipment under test.

Section III. OPERATION UNDER USUAL CONDITIONS

2-6. Preliminary Starting Procedure

Before using the multimeter set, carefully read the operating instructions (para 2-7—2-9) . For maximum accuracy in all measurements, use the range that will produce a meter indication as close to midscale as is possible.

Caution: When measuring unknown voltage or current values, start at the highest range and reduce the range a step at a time until mid-scale deflection is obtained on the meter.

2-7. Voltage Measurements

a. 0 to 1,000 Volts Dc (20,000 Ohms Per volt) .

- (1) Turn the FUNCTION switch to DIRECT (fig. 2-3).
- (2) Plug the black test lead into the OHMS-DC ±AC jack.
- (3) Plug the red test lead into the ap-

propriate range jack in the 20,000 OHMS PE RVOLT DC jacks column.

Warning: If equipment under test has high voltage, be sure that the power is turned off while connecting the test lead prods. Connect the multimeter CASE GROUND jack to the equipment ground or test bench ground as an added safety precaution.

- (4) Connect the black test lead prod to the chassis (ground) and the red test lead prod to the test point of the equipment under test.
- (5) If the meter pointer goes off scale to the left, turn the FUNCTION switch counterclockwise to the REV. position.
- (6) Read the meter indication on the DC scale.

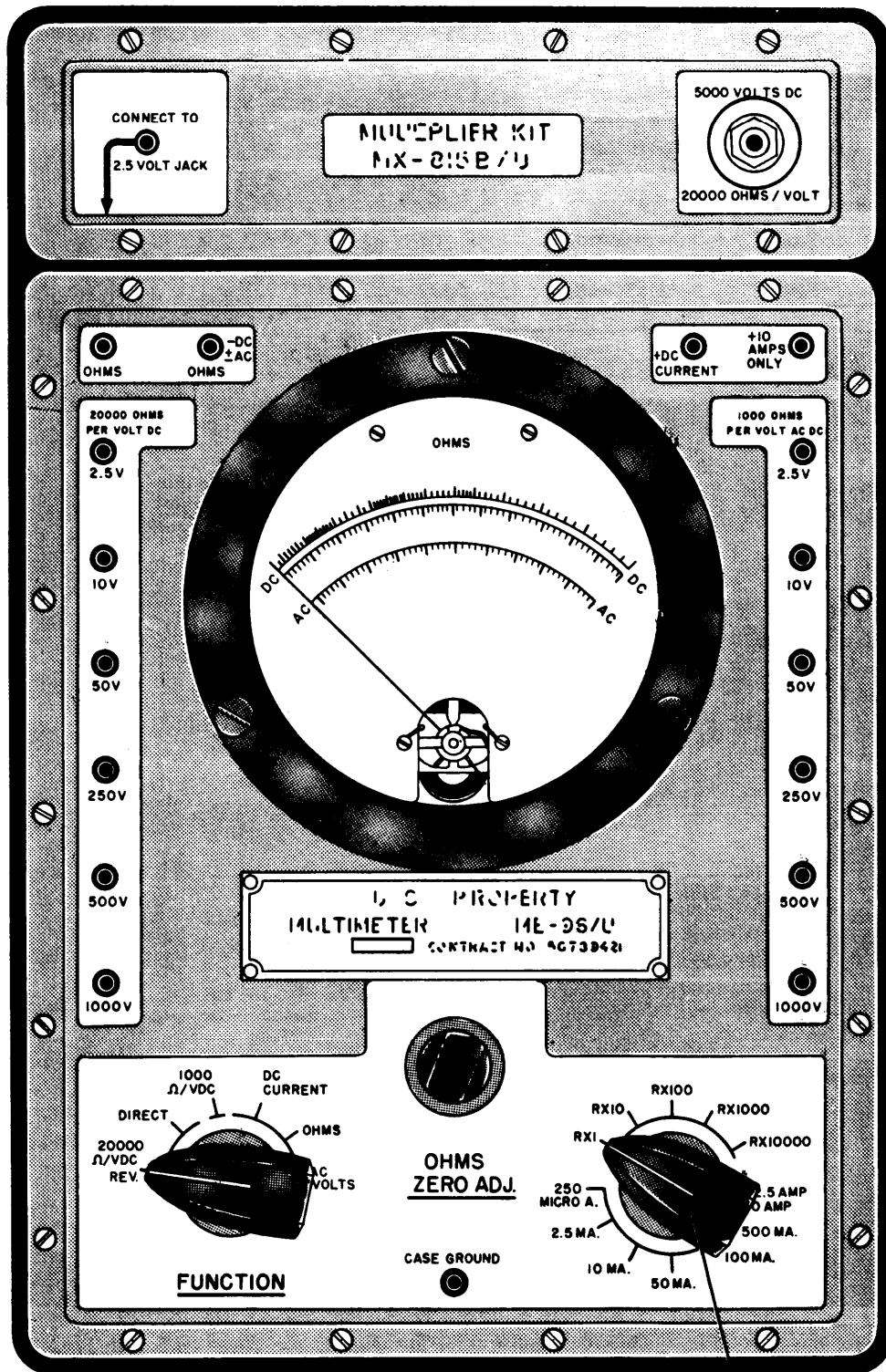

RANGE SWITCH

TM5527-14

Figure 2-3. Panel controls and jack

b. 0 to 5,000 Volts Dc (20,000 Ohms Per volt) .

- (1) Insert Cable Assembly, Special Purpose, Electrical CX 927/U (fig. 1-1) in the 5000 VOLTS DC 20000 OHMS/ VOLT jack of the multiplier (fig. 2-3).
- (2) Connect Cable Assembly, Special Purpose, Electrical CX-939/U (fig. 1-1) between the multiplier and the 2.5V jack (of the 20000 OHMS PER VOLT DC column), on the left side of the multimeter (fig. 2-3).
- (3) Turn the FUNCTION switch to DIRECT.
- (4) Plug the black test lead into the OHMS -DC &AC jack.
- (5) Connect the black test lead prod to the chassis (ground), and the clamp of Cable Assembly, Special Purpose, Electrical CX-927/U to the test point of the equipment under test, and turn on the equipment.
- (6) If the meter pointer goes off scale to the left, turn the FUNCTION switch counterclockwise to the REV. position.
- (7) Read the meter indication on the 0 to 5 DC scale.

c. 0 to 1,000 Volts Dc (1,000 Ohms Per Volt).

- (1) Turn the FUNCTION switch to 1000 Ω /VDC (fig. 2-3).
- (2) Plug the black test lead into the OHMS -DC \pm AC jack.
- (3) Plug the red test lead into the appropriate jack in the 1000 OHMS PER VOLT AC DC jacks column.
- (4) Connect the black test lead prod to the chassis (ground), and the red test lead prod to the test point of the equipment under test.
- (5) If the meter pointer goes off scale to the left, reverse the test lead prods.
- (6) Read the meter indication on the DC scale (fig. 2-3) .

d. 0 to 1,000 Volts Ac.

- (1) Turn the FUNCTION switch to AC VOLTS (fig. 2-3) .

- (2) Plug the black test lead into the OHMS -DC \pm AC jack.
- (3) Plug the red test lead into the appropriate jack in the 1000 OHMS PER VOLT AC DC jacks column.
- (4) Connect the black test lead prod and the red test lead prod to the points in the circuit between which the voltage is to be measured.
- (5) Read the meter indication on the AC scale (fig. 2-3) .

2-8. Procedures for Testing Transistor Circuits

Test transistorized circuits as follows:

a. When measuring resistance, turn off or disconnect the power from the equipment under test. Damage will result from any external voltages which are applied to the ohms circuit of the multimeter.

b. If the equipment contains transistors, and does not have an isolation transformer in its power supply circuit, connect one in the power input circuit. A suitable transformer is identified by Federal Stock No. 5950-256-1779.

c. Make multimeter connections carefully so that shorts will- not be caused by exposed multimeter connectors. Tape or sleeve (spaghetti) test prods or clips to leave as little exposed as needed to make contact to the circuit under test.

d. When the multimeter is used for resistance measurements on transistorized equipment use the RX100 range only. The negative lead of the ohmmeter circuit is connected to the positive side of the battery. The equipment battery (or its equivalent) is recommended as the source of power when servicing transistorized equipment. *Observe battery polarity.* Polarity reversal may damage the transistors or electrolytic capacitors in the circuit. If a battery eliminator is used in place of the battery, it must have good voltage regulation and low ac ripple. Good regulation is important because the output voltage of a battery eliminator, which has poor regulation, may exceed the maximum voltage rating of the transistors in the equipment being tested. A battery eliminator, which has poor ac filtering, will create

a false indication of poor filtering in the equipment being tested.

e. Turn off the transistorized equipment before switching the battery eliminator on or off. The transient voltages, created by switching the battery eliminator on and off, may exceed the *punch-through* rating of the transistors. Make sure that a normal load (such as a speaker for a receiver) is connected to the transistorized equipment before applying power.

f. Refer to the individual technical manual for the equipment being tested.

2-9. Resistance Measurements

a. *Multimeter Zero Adjusting.* Zero adjust the multimeter before making resistance measurements. Each time the range switch is turned to a different resistance range, repeat the zero adjusting procedures as follows:

- (1) Turn the FUNCTION switch to OHMS (fig. 2-3).
- (2) Plug the black test lead into the OHMS-DC±AC jack.
- (3) Plug the red test lead into the OHMS jack.
- (4) Set the range switch to the desired position and touch the two test lead prods together.
- (5) Turn the OHMS ZERO ADJ. knob until meter pointer appears directly over the 0 on the right side of the OHMS scale (fig. 2-3).
- (6) Separate the test lead prods.

b. *Measuring Resistance.*

- (1) Repeat procedures described in a (1), (2), and (3) above.
- (2) If the approximate resistance of the circuit under test is known, turn the range switch to the appropriate resistance range and zero adjust the meter (a (4), (5), and (6) above).
- (3) Connect the test prods across the resistance to be measured.
- (4) Read the meter indication on the OHMS scale (fig. 2-3).
- (5) If the resistance to be measured is unknown, proceed as follows:
 - (a) Set the range switch on the RX10000 range.

(b) Connect the test prods across the unknown resistance.

(c) Turn the range switch counterclockwise, one range at a time, until the meter pointer stops close to midscale.

- (6) Zero adjust the meter (a (4), (5), and (6) above) and read the meter indication on the OHMS scale.

2-10. Direct Current Measurements

Caution: When measuring current, always connect the multimeter in series with the circuit under test. Be sure that the test lead polarity is observed (black-negative and red-positive). Wrong connections may damage the multimeter. Do not measure more than 10 amperes.

a. *Known Current Measurement.*

- (1) Turn the FUNCTION switch to DC CURRENT (fig. 2-3).
- (2) Plug the black test lead into the OHMS -DC & AC jack.
- (3) If the current is known to be more than 2.5 amperes, but less than 10 amperes, plug the red test lead into the +10 AMPS ONLY jack and turn the range switch to 10 AMP (fig. 2-3).
- (4) If the current is known to be less than 2.5 amperes, plug the red test lead into the + DC CURRENT jack (fig. 2-3) and turn the range switch to the appropriate range.
- (5) Connect the test lead prods to the points in the circuit in which the current is to be measured.
- (6) Read the meter indication on the DC scale (fig. 2-3).

b. *Unknown Current Measurement.*

- (1) Determine whether the current to be measured is 10 amperes or less.
- (2) Turn the FUNCTION switch to DC CURRENT (fig. 2-3).
- (3) Plug the black test lead into the OHMS -DC +AC jack.
- (4) Plug the red test lead into the +10 AMPS ONLY jack and turn the range switch to 10 AMP.
- (5) Connect the test lead prods (a (5)

above) and read the meter indication on the DC scale.

- (6) If the meter pointer indicates between 2.5 and 10 amperes, the range selection is correct; read the meter indication.
- (7) If the meter pointer indicates less than 2.5 amperes, turn off the equipment under test and move the red test lead from the +10 AMPS ONLY jack to the \pm DC CURRENT jack.

Do not change the range switch setting.

- (8) Turn on the equipment under test and read the meter indication on the DC scale.
- (9) If the meter pointer does not move close to midscale, turn the range switch clockwise, one range at a time, until a midscale meter indication is obtained.

CHAPTER 3 ORGANIZATIONAL MAINTENANCE

3-1. Scope of Maintenance

The maintenance duties assigned to the organizational maintenance repairman are listed below and in the maintenance allocation chart in appendix C of this manual. The duties assigned do not require any tools or test equipment other than those issued with the equipment.

- a. Monthly preventive maintenance checks and services (para 3-3).
- b. Rustproofing and painting (para 3-5).
- c. Organizational troubleshooting (para 3-6).

servicing and inspection of the equipment to prevent troubles, reduce downtime, and keep the equipment in serviceable condition. Organizational preventive maintenance checks and services are required monthly. Perform the checks and services indicated in paragraph 3-3 once each month. A month is defined as approximately 30 calendar days of an 8-hour day operation. Adjust the maintenance period for any unusual operating conditions. Equipment maintained in standby (ready for operation) condition must receive monthly preventive maintenance checks and services. Equipment in limited storage (requires services before operation) does not require monthly preventive maintenance.

3-2. Preventive Maintenance

Preventive maintenance is the systematic care,

3-3. Organizational Monthly Preventive Maintenance Checks and Services Chart

Sequence No.	Item to be inspected	Procedure	References
1	Publications	Inspect the manual for completeness, and to see if it is in usable condition. Be sure that all changes to the manual are on hand.	DA Pam 310-4.
2	Modification work orders . .	Check to see that all URGENT MWO'S have been applied and that all NORMAL MWOS have been scheduled.	DA Pam 310-7.
3	Completeness	Check the equipment for completeness and general condition.	TM 11-6625-366-10.
4	Cleanliness	Clean the exterior surfaces of the equipment.	Para 3-4.
5	Preservation	Inspect the equipment to determine that it is free of bare spots, rust, and corrosion.	Para 3-5.
6	External receptacles	Inspect the external receptacles for breakage and for firm seating.	
7	Meter glass	Inspect the front panel glass window for damage - housing, broken glass, physical damage, dust, or moisture.	
8	Cables	Inspect the external cables for cuts, cracked or gouged jackets, fraying, or kinks.	
9	Hardware	Inspect all exterior hardware for looseness and damage. The multimeter set cover, carrying handle, hinges and all bolts and screws must be tight and not damaged.	
10	Operation	During operation, be alert for any abnormal indications.	TM 11-6625-366-10.

3-4. Cleaning

Inspect the exterior of the multimeter. The surfaces should be free of dust, dirt, grease, fungus or other foreign matter.

a. Remove the dust and loose dirt with a clean, soft, lint-free cloth or a soft brush.

WARNING

Adequate ventilation must be provided when using TRICHLOROTRIFLUOROETHANE. Prolonged breathing of the vapor must be avoided. The solvent should not be used near heat or open flame; the products of decomposition are toxic and irritating. Since TRICHLOROTRIFLUOROETHANE dissolves natural oils, prolonged contact with the skin should be avoided. When necessary, use gloves that the solvent cannot penetrate. If the solvent is taken internally, consult a physician immediately.

b. Remove grease, fungus and ground-in dirt from exterior surfaces; use a cloth dampened (not wet) with Trichlorotrifluoroethane (Cleaning Compound, Freon, PCA; NSN 6850-00-984-5853 in five gallon cans, or Freon, Type TF; NSN 5850-00-105-3084 in 16-oz cans).

c. Clean plugs and jacks with a soft brush.

CAUTION

Do not press on meter glass when cleaning; the meter may be damaged.

d. Clean the meter front panel, meter glass

and control knobs with a soft, clean cloth. If necessary, dampen the cloth with water. Mild soap may be used for more effective cleaning.

3-5. Rustproofing and Painting

a. *Rustproofing.* When the finish on the multi meter set has become badly scarred or damaged, rust and corrosion can be prevented by touching up the bare surfaces. Use No. 000 sandpaper to clean the surface down to the bare metal. Obtain a bright, clean surface.

b. *Painting.* Remove rust and corrosion by light sanding. Brush two thin coats of paint on the bare metal to protect it from further corrosion. Refer to the applicable cleaning and refinishing practices in TB 43-0118.

3-6. General Troubleshooting information

Troubleshooting this equipment is based on the operational checks outlined in TM 11-6625-366-10. To troubleshoot the equipment, perform all of the multimeter functions and proceed until an abnormal indication is obtained. Note the abnormal condition or result and refer to the troubleshooting chart in paragraph 3-7. Find the symptom and the corrective measure recommended. If the measures indicated do not correct the problem, refer the instrument to higher level maintenance. Paragraph 3-8 contains some basic repair information for the organizational maintenance level.

3-7. Troubleshooting Chart

Item No.	Trouble symptom	Probable trouble	Checks and corrective measures
1	Meter does not indicate.	a. Open test leads b. Corroded or dirty test lead prods. c. Defective meter	a. Repair, or replace test leads b. Clean test lead prods. c. Refer to a higher maintenance category.
2	Meter does not indicate within tolerance.	a. Defective multiplier resistor, or resistors. b. Defective compensating network. c. Defective meter shunt	Refer to a higher maintenance category.
3	Meter does not indicate on AC ranges.	Defective rectifier	Refer to a higher maintenance category.
4	Multimeter cannot be zero adjusted on RX1, RX10, RX100, and RX1000 ranges.	Weak or defective Battery BA-30 (1.5 volt).	Replace battery BA-30 (TM 11-6625-366-10).
5	Multimeter cannot be zero adjusted on RX10000 range.	Weak or defective Batteries BA-31 (4.5 volts each).	Replace batteries BA-31 (TM 114625-366-10).
6	Multimeter zero adjustment is erratic on all ranges, or a meter cannot be zero adjusted on any range.	a. Defective OHMS ZERO ADJ. potentiometer. b. Defective test leads c. Defective batteries d. Poor connections on batteries.	a. Refer to a higher maintenance category. b. Relate test leads. c. Replace batteries. d. Clean and tighten the battery connectors.

3-8. Repairs

a. *Removal of Batteries.* For removal of batteries in the multimeter, refer to the step by-step procedure for battery installation given in TM 11-6625-366-10.

b. *Replacement of Knobs.* Determine whether may or all of the three knobs on the front panel of the multimeter use a slotter-head or an allenhead setscrew. The procedure for the replacement of knobs is given in (1) through (6) below.

CAUTION

The use of improper tools for this procedure may result in damage to the setscrew or knob bushing, making replacement of the knob difficult.

(1) Loosen the setscrew of the knob to be replaced by turning the screw counterclockwise.

The setscrew should be loosened enough so that the knob is free on its shaft.

- (2) Lift and remove the knob from its shaft.
- (3) Inspect the replacement knob to make sure that its setscrew does *not* protrude beyond the inside of the knob bushing. Check the bushing, and make any necessary adjustment with the proper wrench or screwdriver by turning the setscrew counterclockwise.
- (4) Place the knob on its shaft and index it to the proper setting.
- (5) Make sure that the setscrew is in line with the flat side of the shaft.
- (6) Tighten the setscrew by turning the screw in a clockwise direction.

FUNCTIONING OF MULTIMETER TS-352B/U

4-1. Block Diagram

(fig. 4-1)

a. Multimeter TS-352B/U is a multi range ac- and dc-volt ohm milliammeter using a single moving coil, 50-microampere meter of the D'Arsonval type, with appropriate scales marked to indicate ac and dc volts, dc current, and resistance in ohms.

b. The voltmeter circuit is essentially a meter with series multiplier resistors. The multiplier resistors are the same for ac and dc measurements. However, since the meter is a dc milliammeter, the ac-voltage input must be rectified before being applied to the meter.

c. Wafer switches are used in the switching circuits to control the functions and ranges of the multimeter. All meter shunt resistors and some multiplier resistors are selected by the positioning of the contacts in the switching circuits. The switching circuits also connect the battery, or batteries, and appropriate shunt and series resistors into the necessary

circuit arrangements for resistance measurements in the different ohmmeter ranges.

d. All connections between the multimeter set and the equipment under test are made with a pair of test leads equipped with pin plugs which mate with the jacks (except for the banana jack used in the high voltage multiplier) located on the multimeter panel.

e. Voltmeter multiplier resistors are connected between the voltmeter jacks and the switching circuits, and the desired range is selected by the use of the jack marked with the desired voltage value.

f. Direct current and ohmmeter ranges are selected by the range switch.

4-2. Dc Voltmeter Circuit (1 ,000 Ohms Per volt)

(fig. 4-2)

a. The application of a dc voltage (within the limits of the voltage values marked adjacent to the selected jacks) between the 1000V

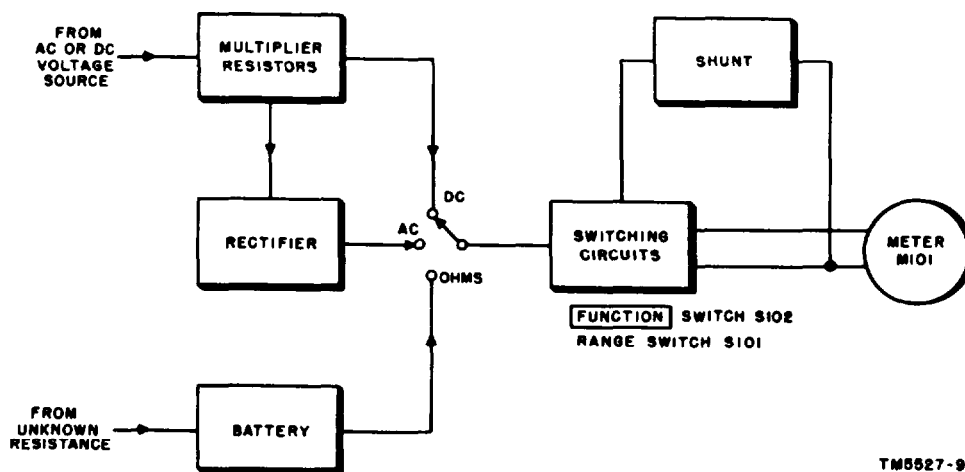

Figure 4-1. Block diagram of multimeter.

jack in the 1000 OHMS PER VOLT column, and the OHMS — DC \pm AC jack, causes a current to flow as follows:

- (1) Current flows from OHMS — DC \pm AC jack to the point of division (B, fig. 4-2).
- (2) At point B, the current divides, and flows through the shunt network consisting of resistors R112, R129, R138, R137, R136, R135, R134, and R132, and also through the meter network consisting of meter M101, switch S102, resistors R139 and R131.
- (3) At full scale deflection, the shunt resistors provide a current path for 950 microampere around meter M101: only 50 microampere will pass through the meter.
- (4) The two currents meet at point A (fig. 4-2) and, since FUNCTION switch S102 is in the 1000V/ VDC position, the current passes through resistor RI 30 and switch S102.
- (5) The current now flows through series-connected multiplier resistors R101, R102, R103, R104, and R105, and onto the 1000V jack.

b. The compensating network, consisting of resistor R139A and R139B, provides temperature compensation of the multimeter. When the temperature rises, the resistance of all the resistors rises slightly. The effect of the compensating network is to maintain a constant overall resistance value of the multimeter resistors to within the rated tolerances (para 1-5).

c. With the application of a dc voltage between the 500V jack and OHMS —DC \pm AC jack, the path taken by the current is the same as described in *a* above, except that resistor R105 would be out of the circuit. Accordingly, if the 2.5V jack were used, all the series-connected multiplier resistors would be out of the circuit.

d. Since, as shown in *c* above, the use of lower value series-connected multiplier resistors is required in the measurement of a lower voltage, the principle governing the use of multipliers in the voltmeter circuit becomes

evident. The *higher* the voltage being measured, the *higher* the resistance that must be placed in the current path to limit the current to that which the meter needs to deflect the pointer the required amount. The *lower* the voltage being measured, the *lower* the resistance required to limit the current through meter M101 to the proper value.

4-3. Dc Voltmeter Circuit (20,000 Ohms Per Volt) (fig. 4-3)

a. The principle governing the use of multiplier resistors in the 20,000-ohm-per-volt dc voltmeter circuit of the multimeter set is similar to the 1,000-ohm-per-volt dc voltmeter circuit described in paragraph 4-2. However, the omission of the shunt resistors and temperature compensating network, and the introduction of a polarity reversing circuit mark the chief differences between the two voltmeter circuits. The path taken by the current through the 20,000-ohm-per-volt voltmeter circuit is as follows:

- (1) With the application of a dc voltage between the 1000V jack, and the OHMS — DC \pm AC jack, current flows through the meter and through the series-connected multiplier resistors RI06, RI07, R108, R109, R110, and R111.
- (2) With FUNCTION switch S102 in the 20000 Ω /VDC DIRECT position, the terminals of the switches shown in figure 4-3 are connected in a circuit arrangement that directs the current through the meter, as shown by the solid lines.
- (3) With FUNCTION switch S102 in the 20000 Ω /VDC REV. position, the circuit is so arranged that multi meter jacks marked with the voltage values are connected to the *negative* side of the voltage source. Current flow through meter M101, however, remains in the same direction. This current path is shown in figure 4-3 as a broken line portion of the entire circuit.

b. The current flow through the 20,000-ohm-per-volt circuit is 50 microamperes when the

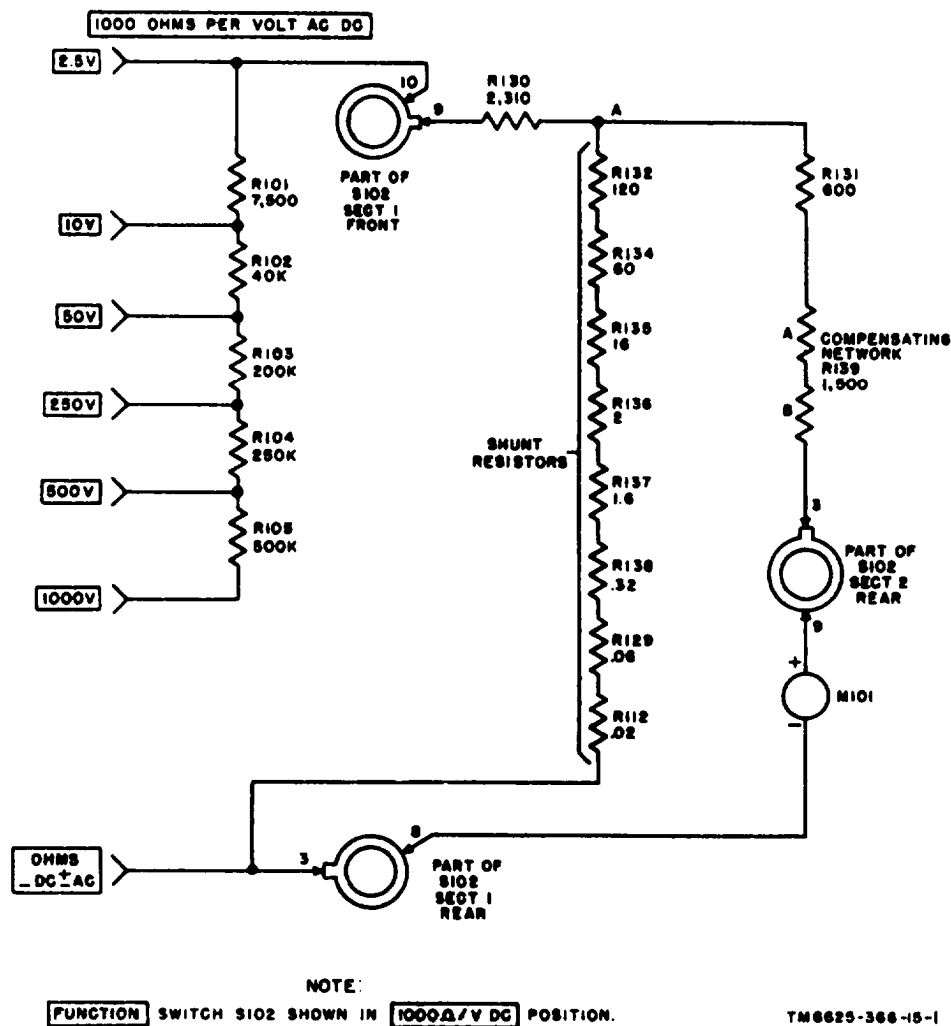

Figure 4-2. DC voltmeter circuit (1,000 ohms per volt), simplified schematic diagram.

meter indicates full scale. The function of all the series-connected multiplier resistors (*a* (1) above) is to drop the voltage applied to the multimeter jacks down to the value which causes only 60 microampere to flow through the meter at full deflection.

c. Since the current flow through the 20,000-ohm-per-volt circuit is normally never higher than 60 microampere, no shunt circuit is used across meter M101. The omission of the shunt circuit and the use of extremely high values of series-connected multiplier resistors, provides high sensitivity. The voltmeter may be placed across a voltage source in a very high resistance circuit and, because the voltmeter draws

only 60 microampere for full-scale deflection, the voltage drop across this high resistance circuit will be very low; the voltmeter indication therefore will be nearer to the true value of voltage across that particular circuit.

d. The value of the high voltage multiplier resistor is such that with 6,000 volts applied between the banana jack marked 6000 VOLTS DC 20000 OHMS/VOLT, and the OHMS - DC ±AC jack (fig. 8.1), only 2.6 volts will appear between the 2.5V jack and the OHMS -DC ±AC jack. Since the current flow in the 20,000-ohm-per-volt circuit is 60 microampere, the meter will indicate the 2.6 volts in terms of 6,000 volts on the 0-6 scale; the marking 5 coincides with 2.5.

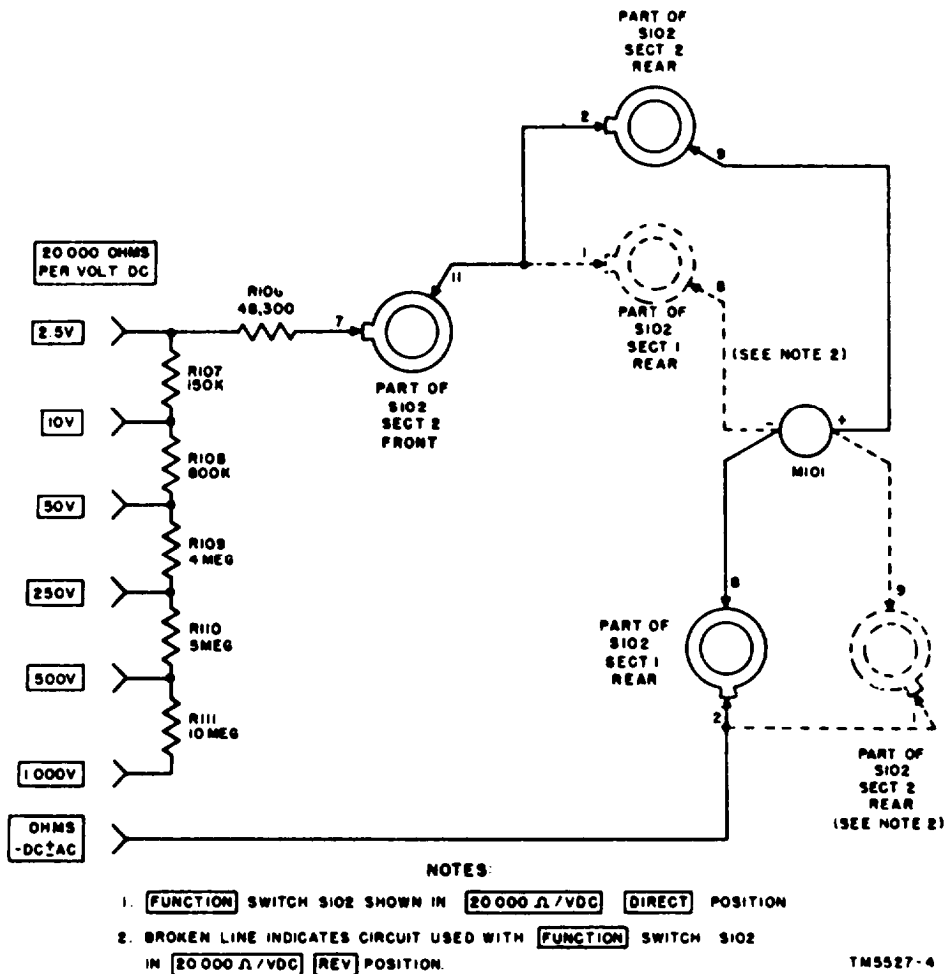

Figure 4-3. Dc voltmeter circuit (20,000 ohms per volt), simplified schematic diagram.

4-4. Ac Voltmeter Circuit

a. The functioning of the ac voltmeter circuit is similar to that described for the dc voltmeter circuits (paras 4-2 and 4-3), except for the action of the full-wave rectifier (on ac resistor board A101) and its associated resistors. The same series-connected multiplier resistors are used (R101, R102, R103, R104, and R105) as in the 1,000-ohm-per-volt dc voltmeter circuit. However, regardless of the ac voltage applied to the jacks (within the marked values at the appropriate jacks), 2.5-volts ac will appear across the two input leads to the rectifier circuit for full-scale meter deflection (these leads are marked AC on figure 4-4). The functioning of the rectifier action is given in b below.

b. During the ac cycle when the polarity of

the incoming ac is negative at the OHMS - DC ±AC jack, rectifier B (fig. 4-4) conducts, and current flows through loading resistor R1.43, through the rectifier, resistors R141 and R145, and back to the other side of the incoming at-voltage source.

c. With a reversal in polarity of the incoming ac, current flows through resistors R145 and R141, rectifier A, loading resistor R144, and back to the source.

d. Resistors R143 and R144 are voltage-dropping resistors across which the dc potentials are developed. The negative terminal of meter M 101 is connected to the negative end of loading resistor R144 through terminals 6 and 8 of the rear of section 1 of FUNCTION switch S102. The positive terminal of meter

M101 is connected to the positive end of load- ing resistor R143 through terminals 6 and 9 of the rear of section 2 of FUNCTION switch S102, current limiting resistor R140, and cali- brating resistor R146. Calibrating resistor R146 compensates for slight differences in rectifier characteristics. Resistors R145, R141, and R 142 from a T-pad which matches the rectifier circuit impedance with the impedance

of the circuit external to the rectifier.

e. At full-scale deflection of meter M101, 1 milliampere flows in the ac voltmeter circuit. Meter M101 draws 50 microampere; the re- maining 950 microampere is drawn by the circuit made up of the rectifier and its as- sociated resistors. Resistor R142, the shunt resistor of the T-pad, passes **most** of this current.

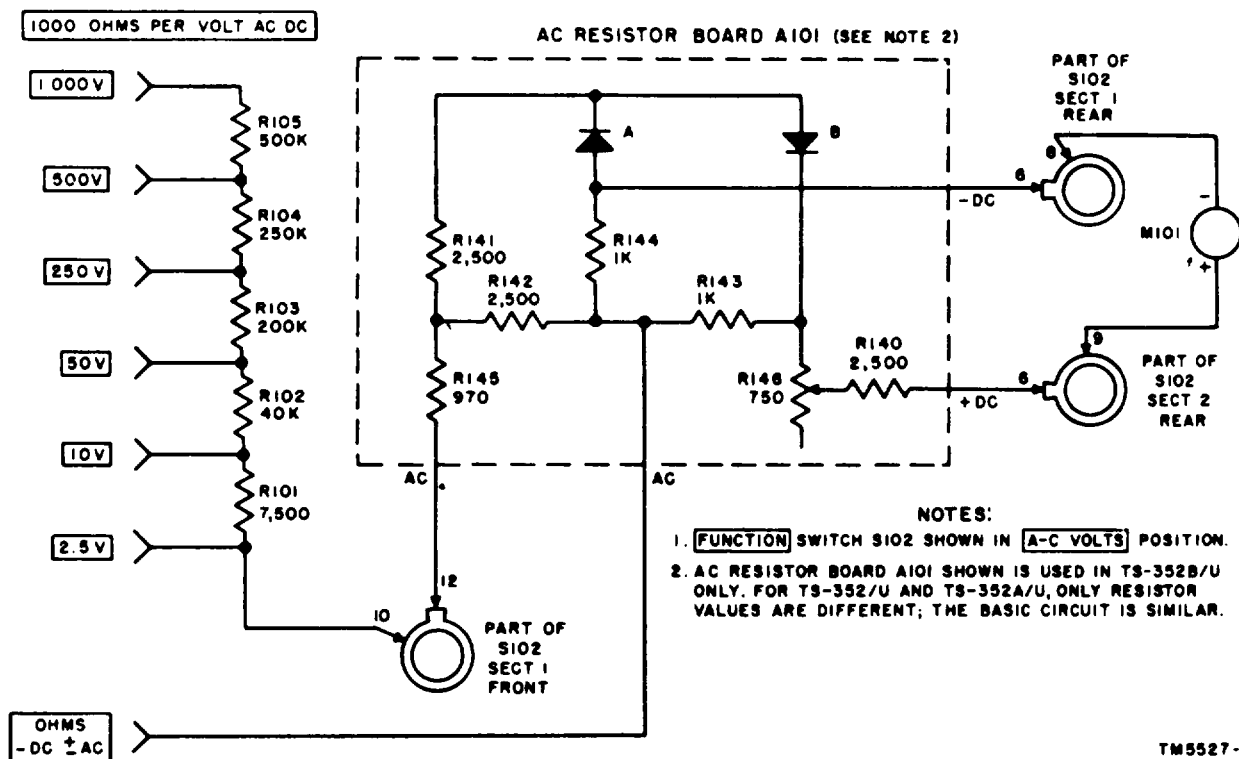

Figure 4-4. Ac voltmeter circuit, simplified schematic diagram.

4-5. Ohmmeter Circuit (fig. 4-5)

a. *General.* The ohmmeter circuit used in the TS-352B/U is the voltage divider type. Different values of shunt resistors are connected in circuit combinations that tend to reduce meter scale crowding, and provide more even distribution of the scale divisions for the five ohmmeter ranges of the multimeter. A 1.5-volt self-contained dry battery provides the operating current for all but the highest ohmmeter range. Three 4½- volt batteries and the 1½-volt battery in series (15 volts) provide

the operating current for the highest range,

b. Lower Ohmmeter Ranges.

- (1) With an unknown resistance connected between the OHMS - DC ±AC jack and the OHMS jack, FUNCTION switch S102 in the OHMS position, and range switch S101 in the RX1 position, the following circuit is established (fig. 4-5) :

(a) Current flows from the negative terminal of the 1.5-volt battery, through the unknown resistor, to

the junction of shunt resistor R117 and variable resistor R118 (OHMS ZERO ADJ.) where it divides. Part of the current flows through variable resistor R118 and resistor R120, through resistors R123 and R125, and back to the positive terminal of the 1.5-volt battery.

- (b) Meter M101, acting as a voltmeter connected through limiting resistor R123, is across resistor R117, part of a voltage-dividing network consisting of shunt resistors R125, R117, and the unknown resistor. the meter indicates the voltage drop across resistor R117.
- (2) If the ohmmeter test leads were shorted, the meter would indicate full-scale. However, if a low value of resistance is placed between the ohmmeter test leads ((1) above), less current will flow through the shunt resistors; the voltage drop will be less and, therefore, the meter indication will be less than full-scale. Actually, the meter is indicating the lower voltage in terms of a lower value of ohms or dc resistance.
- (3) With range switch S101 in the RX10 position, shunt resistors R119 and R126 are connected across the battery. Since the value of these resistors is approximately 10 times the value of the resistors used in the RX1 range, only about one-tenth of the current will flow through them. Consequently, the voltage drop across resistor R119 will be about the same as it was across resistor R117. Therefore, meter M101 will indicate 10 times the resistance with the same amount of needle deflection. In other words, the indication of 30 ohms on the RX1 range is read as 300 ohms on the RX10 range.
- (4) Variable resistor R118 compensates for changes in battery voltage because of age, and also for heavy current drain from the lower value shunt

resistors. Resistor R120 maintains a minimum value shunt across the meter to prevent more than a 50-microampere current from flowing through the meter, regardless of the resistance values selected by the range switch.

- (5) On the RX1000 range, meter M101 indicates the voltage drop across variable resistor R118 and resistor R120. Resistors R128, R123, and the unknown resistor then become part of the voltage-dividing network.

c. *Highest Ohmmeter Range.*

- (1) The circuit selected by FUNCTION switch S102 and range switch S101 for the highest ohmmeter range (RX10000) is the same as the circuit used for the RX 1000 range, except that resistor R124 is substituted for resistor R128 (b (5) above) and 15 volts are used instead of 1.5 volts. Meter M101, acting as a voltmeter, indicates the voltage drop across variable resistor R118 and resistor R120.
- (2) With an unknown resistance between the OHMS jack and the OHMS - DC \pm AC jack, the current flow is as follows :
 - (a) From the negative terminal of the 1.5-volt battery the current flows through the unknown resistor, through shunt resistors R118 and R120, through resistors R123 and R124, to the positive terminal of the 13.5-volt battery (three 4 $\frac{1}{2}$ -volt batteries connected in series).
 - (b) The circuit is completed through the batteries to the OHMS jack. Since the 1.5-volt battery is connected in series with the 13.5-volt battery, the total is 15 volts. The 15-volt power supply is required on the RX10000 range to develop the necessary voltage drop for meter M101 to indicate full-scale with zero resistance between the ohmmeter test leads.

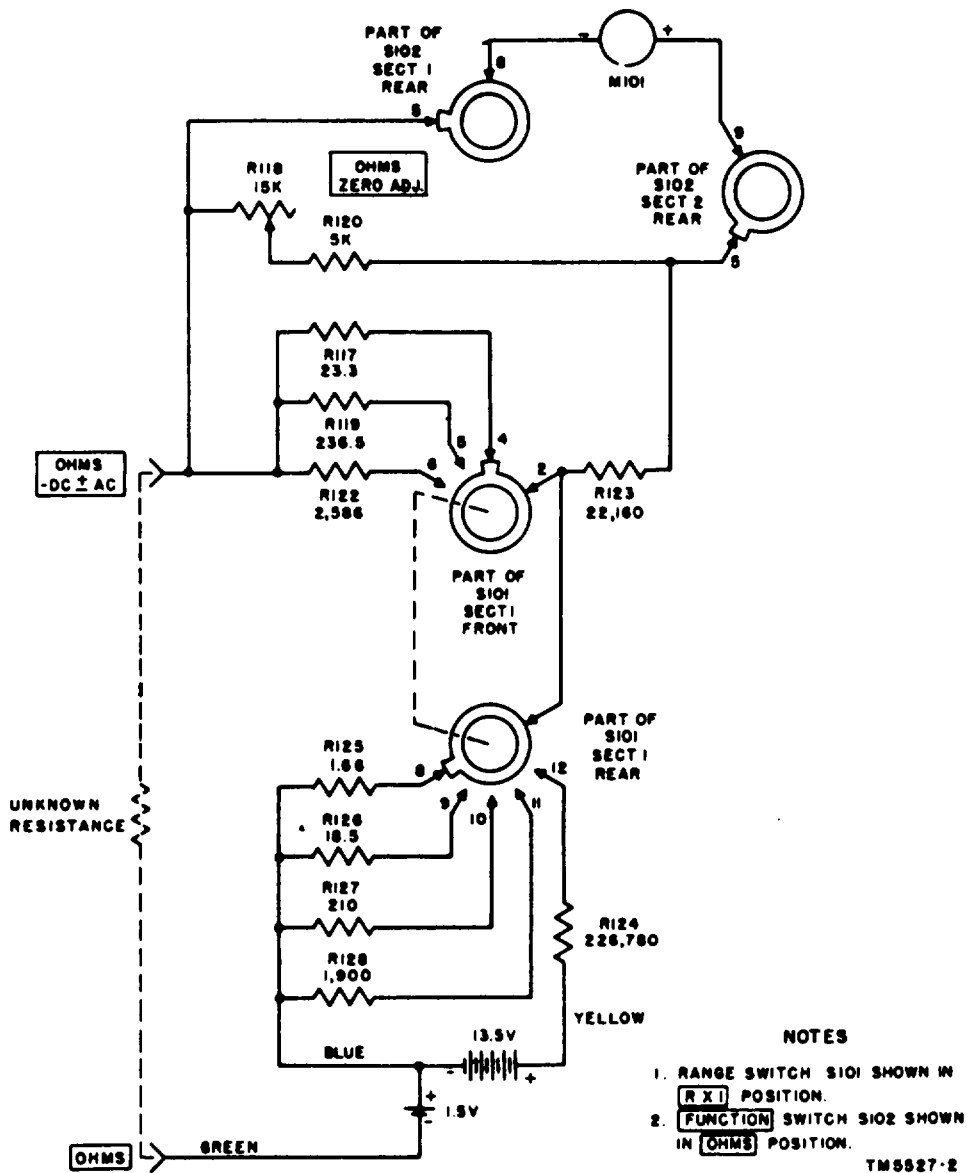

Figure 4-5. Ohmmeter circuit, simplified schematic diagram.

4-6. Direct Current Circuit (fig. 4-6)

c. With FUNCTION switch S102 in the DC CURRENT position, and range switch S101 in the 2.5 AMP position, the direct current circuit is arranged to divert all the current entering and leaving the multimeter through resistors R112 and R129, except for the 60 microampere required for full-scale deflection of meter M101. As shown in figure 4-6, meter M101 is connected across the shunt resistor network

through resistor R139A and its compensating element R139B which make up the temperature compensating network.

b. With the range switch in the other positions, shunt resistors are added in predetermined amounts across the meter to divert all but the required 50 microampere of current for a full-scale deflection. Figure 4-6 shows that the value of shunt resistor R137 is approximately five times the value of shunt resistor R138. Refer to the multimeter panel

esignations that correspond to the switch positions using these shunt resistors. Note that the 600 MA. position uses a shunt resistor (R138) approximately one-fifth of the value of the resistor (R137) used in the 100 MA. position. In other words, the higher the current range of the meter, the lower the value of the shunt circuit around the meter. The lower the current range, the higher the shunt value. Regardless of the amount of the current being measured, the meter passes only 60

microamperes for full-scale deflection.

c. With the range switch in the 2.5 AM position, the multimeter will also indicate 0. the 10-ampere range of the meter. When the range switch is in this position, shunt resistor R112 (actually a short length of wire) carries the 10 amperes less the 50 microampere used to operate the meter. The meter is connected to the +10 AMPS ONLY jack and the OHMS - DC \pm AC jack through compensating network R139A and R139B, and resistor R129.

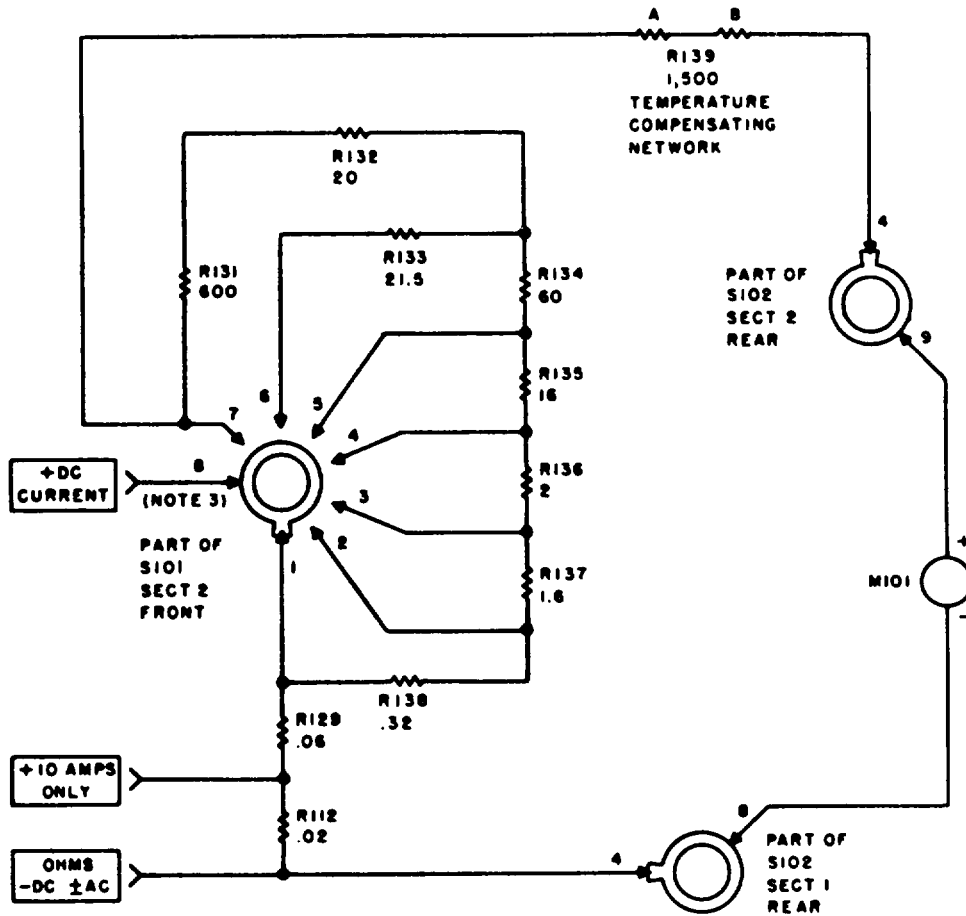

NOTES:

1. **FUNCTION** SWITCH S102 SHOWN IN **DC CURRENT** POSITION.
2. RANGE SWITCH S101 SHOWN IN **2.5 AMP** POSITION.
3. ON TS-352/U AND TS-352A/U, TERMINAL 12 IS USED INSTEAD OF TERMINAL 8.

TM5527-CI-1

Figure 4-6. Direct current circuit, simplified schematic diagram.

CHAPTER 5
GENERAL SUPPORT MAINTENANCE

Section I. TROUBLESHOOTING

5-1. General Instructions

Examine the shunt and multiplier resistors, connectors, soldered connections, and the meter for defects before setting up elaborate test equipment. If the multimeter set operator's complaint is available, study it for possible clues to cause of trouble. Avoid looking for the unusual trouble. Some troubles can be located by consulting the troubleshooting procedures (para 5-3) and the troubleshooting chart (para 5-4).

5-2. Organization of Troubleshooting Procedures

a. General. The first step in servicing a defective multimeter is to localize the fault. Localization means tracing the fault to a defective stage or circuit responsible for the abnormal condition. The second step is isolation. Isolation means locating a defective part or parts. Some defective parts, such as burned resistors and arcing or shorted rectifiers, can be located by sight, smell, or hearing. Most defective parts, however, must be isolated by checking voltage and resistance.

b. Localization and Isolation.

- (1) *Localization.* To localize trouble to a stage or circuit in the suspected unit, perform localization procedures given in paragraph 5-3.
- (2) *Isolation.* Procedures for isolating troubles are given in paragraph 5-3, which also lists the tools and test equipment necessary for isolating procedures.

5-3. Localizing and Isolating Troubles

a. Tools and Test Equipment Required. Tools and test equipment required for troubleshooting at the general support maintenance

category are Tool Kit, Electronic Equipment TK-100/G and Multimeter TS-352B/ U.

b. Troubleshooting Precaution.

- (1) The TS-352B/U ohmmeter circuit used for testing the multimeter requires considerable current for its operation; the lower the range, the greater the amount of operating current. Therefore, do not attempt to check the continuity of meter M101 suspected of being open. Meter M101 has a 50-microampere movement and will be damaged by the excessive current flow.
- (2) Before concluding the values of resistance in a circuit under test, always consult the schematic diagram (fig. 8-3) or the simplified diagram showing the circuit concerned (fig. 4-1 through 4-6). Switches S101 and S102 place resistors in series and in shunt with meter M101 and, before final ohmmeter readings can be considered conclusive, these series and shunt circuit values must be considered. It is good practice to unsolder a resistor from the circuit before measuring its value. This action does not apply to an open series multiplier resistor, such as resistors R101 through R105 and resistors R106 through R111. These resistors are series resistors with no shunting circuits; also, their continuity can be determined by using the appropriate multimeter jacks as points of connection by the testing multimeter.
- (3) Voltages across circuits being checked for continuity can damage the ohm-

meter circuits of the testing multimeter. Therefore, before applying test leads to the testing points on the multimeter chassis, be sure the battery of the multimeter being checked is disconnected.

- (4) The dc resistance of the multimeter set high voltage multiplier resistor is too high to be indicated accurately on the TS-352B/U ohmmeter. Therefore, do not accept the slight ohmmeter needle flicker as being indicative of normal dc resistance of this high voltage multiplier resistor. Instead, connect the high voltage multiplier to a multi meter known to be good, and measure dc volts (para 2-7) .
- (5) Consult the diagram of the ac resistor board (fig. 8-3) used with the TS-352B/U. Multimeters of different manufacture have minor ac resistor board A101 wiring and circuit differences (although functionally alike) that are not represented on figure 8-3. Therefore, if ac resistor board A101 in one of these multimeters is suspected of being faulty (false ac voltage indication on the multimeter), try another identical ac resistor board and note the differences in ac voltage indication (para 2-7).
- (6) The dry batteries used in the multimeter have an end voltage below which the batteries are useless. Inability to bring the ohmmeter pointer to zero on the right end of the ohmmeter scale is an indication of

exhausted batteries; therefore, a normal indication of battery voltage the scale of a 1,000 -ohm-per-voltmeter may be false. Either measure the battery voltage with a suitable load, or replace the suspected battery.

- (7) Resistor R112 is the shunt resistor for the 0- to 10-ampere range of the dc current function of the multimeter. This shunt resistor is a short length of bare wire resembling a piece of bus wire commonly used as grounding leads (fig. 5-1). Do not shorten, cut, unsolder and resolder this resistor. Its dc resistance is too low to be measured accurately with a TS-352B/U. On the lowest resistance scale of the multimeter, resistor R112 (as well as resistor R129, shunt resistor for the 2.5 AMP circuit) will be indicated as practically full-scale, or zero ohms.
- (8) The tolerance of most of the resistors used in the multimeter set is plus or minus one-half percent. The accuracy of the TS-352B/U ohmmeter circuit is approximately plus or minus 3 percent in terms of the ohmmeter scale length (not in ohms of dc resistance). Therefore, if symptoms indicate the value of a particular resistor, shunt or series to be off tolerance, the TS-352BU ohmmeter cannot be used to determine how much off it is. Replace the resistor with a known good one and note whether the symptoms disappear.

5-4 Troubleshooting Chart

Item No.	Trouble symptom	Probable trouble	Checks and corrective measures
1	Multimeter fails to operate on any function.	<ul style="list-style-type: none"> a. Defective test leads ----- b. Defective meter M101 c. Defective FUNCTION switch S102. d. Defective jacks 	<ul style="list-style-type: none"> a. Repair or replace test leads. b. Replace meter M101. c. Replace FUNCTION switch S102. d. Repair or replace jacks.
2	Multimeter indicates low on all functions.	Defective meter M101	Replace meter M101.

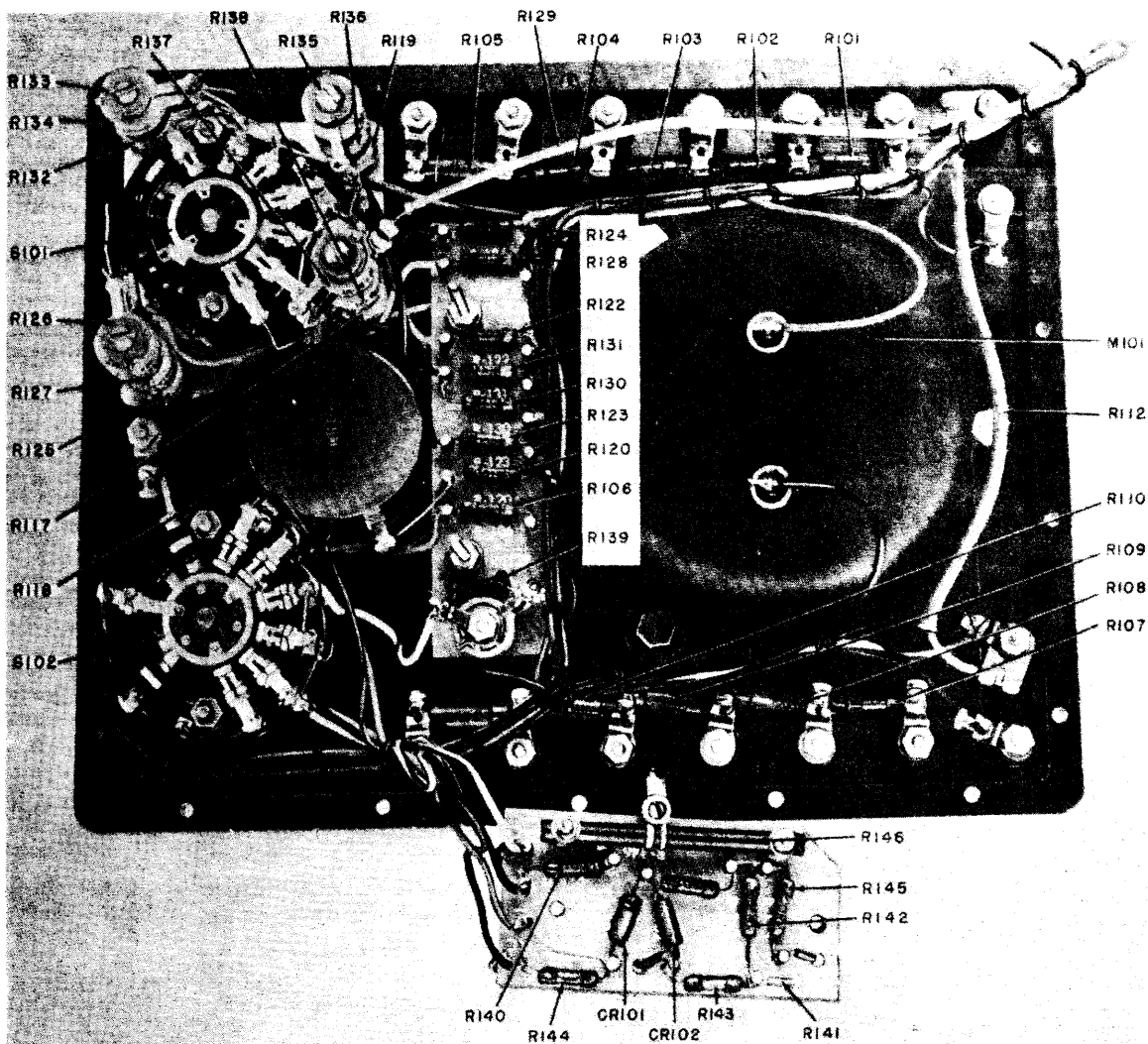

TM5527-8

Figure 5-1. Multimeter TS452B/U, rear view.

Item No.	Trouble symptom	Probable trouble	Checks and corrective measures
3	Multimeter cannot be zero adjusted on any resistance range.	<i>a.</i> Weak batteries _____ <i>b.</i> Range switch S101 open __	<i>a.</i> Replace batteries (para 5-3 <i>b</i> (6)). <i>b.</i> Repair or replace range switch S101.
4	Multimeter does not indicate on RX1 through RX1000 ranges.	<i>a.</i> Battery BA-30 dead _____ <i>b.</i> Resistor R123, or one of resistors R125 through R128 open.	<i>a.</i> Replace Battery BA-30 (para 5-3 <i>b</i> (6)). <i>b.</i> Replace resistor R123, or one of resistors R125 through R128 (para 5-3 <i>b</i> (2) and (8)).
5	Multimeter does not indicate on one or more ranges of the 20,000-ohm-per-volt function.	One of resistors R106 through R111 open.	Replace one of the resistors R106 through R111.

Item No.	Trouble symptom	Probable trouble	Checks and corrective measures
6	Multimeter does not indicate on 5,000-volt range of the 20,000-ohm-per-volt function.	<i>a.</i> Open Cable Assembly, Special Purpose, Electrical CX-939/U. <i>b.</i> Open Cable Assembly, Special Purpose, Electrical CX-927/U. <i>c.</i> Open multiplier resistor in multiplier.	<i>a.</i> Replace Cable Assembly, Special Purpose, Electrical CX-939/U (para 3-5). <i>b.</i> Replace Cable Assembly, Special Purpose, Electrical CX-927/U. <i>c.</i> Replace multiplier (para 5-3 <i>b</i> (4)).
7	Multiplier does not indicate on one or more of the 1,000-ohm-per-volt function.	One of multiplier resistors R101 through R105 open.	Replace one of multiplier resistors R101 through R105.
8	Multimeter indicates low on all ac ranges.	Defective rectifiers ___ - - - - -	Replace rectifiers CR101 and CR102.
9	Multimeter does not indicate on any direct current range (current or voltage).	Resistor R139A or R139B open.	Replace resistor R139A or R139B (para 5-3 <i>b</i> (2) and (8)).
10	Erratic multimeter operation _	Contact on switches S101 and S102 oxidized.	Clean switch contacts with cleaning compound.

Section II. ALIGNMENT

5-5. General

The only alignment procedure to be performed on the multimeter is covered in paragraph 5-6. The equipment required for alignment is Meter Test Set TS-682/GSM-1.

5-6. Alignment Procedure

Align Multimeter TS-352B/U, as follows:

a. Remove the multimeter chassis from the case.

b. Remove the nuts that secure ac resistor board A101 to the chassis. Do not disconnect any wires.

c. Set the multimeter for operation on the 10-volt ac range (para 2-7 *d*).

d. Set the output voltage of Meter Test Set TS-682/GSM-1 at 10 volts ac.

e. Connect the multimeter test leads to the TS-682/GSM-1.

f. Adjust the calibration resistor (slide wire resistor mounted on A101) until the meter pointer indicates 10 volts ac.

g. Reassemble the multimeter.

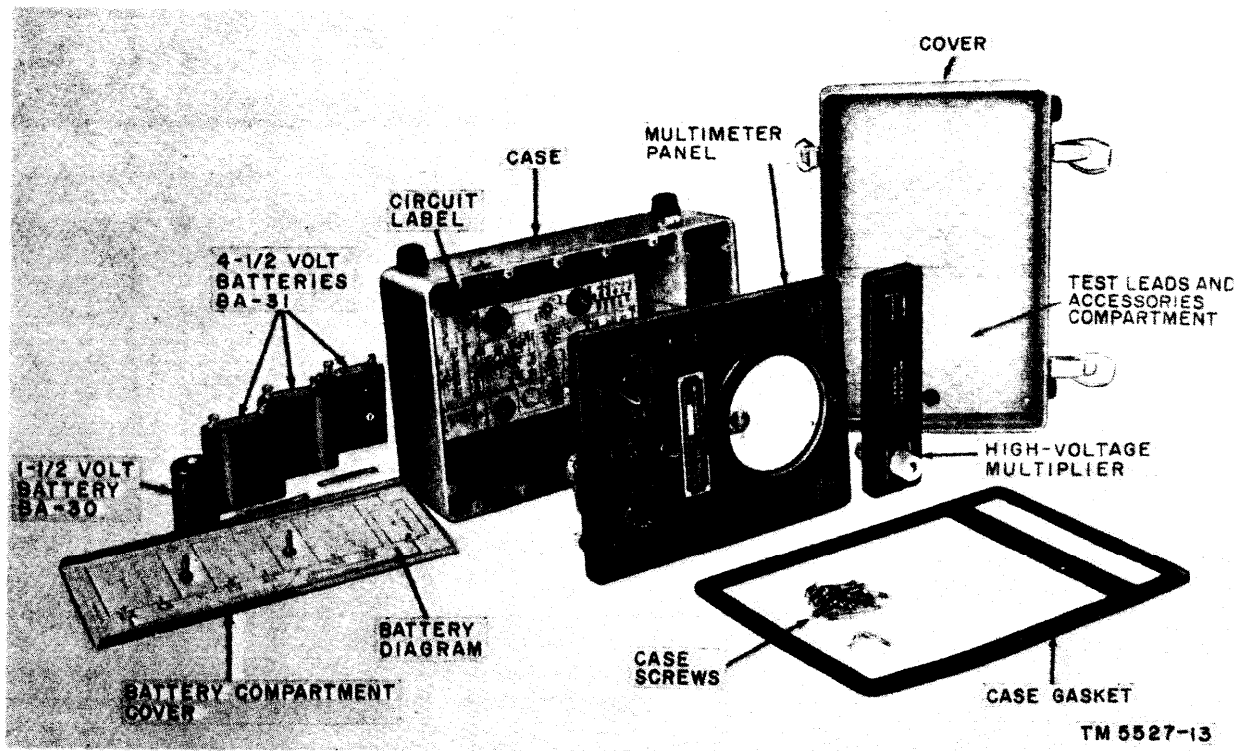

Figure 5-2. Multimeter TS-352B/U exploded view.

CHAPTER 6

GENERAL SUPPORT TESTING PROCEDURES

6-1. General

a. Testing procedures are prepared for use by Electronics Field Maintenance Shops and Electronics Service Organizations responsible for general support maintenance of repaired equipment. These procedures set forth specific requirements that repaired equipment *must* meet before it is returned to the using organization. These procedures may also be used as a guide for testing equipment that has been repaired at direct support maintenance if the proper tools and test equipments are available.

b. Comply with the instructions preceding each chart before proceeding to the chart. Perform each step in sequence. For each step,

perform all the actions required in the Control *settings* column; then perform each specific test procedure and verify it against its performance standard.

6-2. Lost Equipment and Materials Required

All test equipment and materials required to perform the testing procedures given in this section are listed in the charts below, and are authorized under TA 11-17, Signal Field Maintenance Shops, and TA 11-100(11-17), Allowances of Army Corps Expendable Supplies for Signal Field Maintenance Shop, Continental United States.

a. *Test Equipment.*

Nomenclature	Federal stock No.	Technical manual
Meter Test Set TS-682/GSM-1 _____ or Meter Test Set TS-632A/GSM-1	6625-669-0747 (Same stock number as unlettered model)	TM 11-6625-277-14
Decade Resistor ZM-16(*)/U* _____	6625-669-0266 _____	TM 11-5102

*Indicates models ZM-16/U and ZM-16A/U.

b. *Test Materials.*

Nomenclature	Federal stock No.	Technical manual
Power Supply PP-1104A/G or Battery BA-46 (wet) _____ Battery BA-30 (1 ea) _____ Battery BA-31 (3 ea) _____	6130-635-4900 _____ 6140-128-8706 _____ 6135-120-1020 _____ 6135-120-1019 _____	TM 11-5126

6-3. Test Facilities

a. When performing the dc ammeter function test (para 6-10), a 12-volt dc power source capable of supplying a minimum of 20 amperes of dc is required to power the meter test Set.

b. To perform the ohmmeter function test (para 6-7), see that the dry batteries listed in the chart (para 6-2 b) are installed in the multimeter under test.

6-4. Modification Work Orders (MWO'S)

The performance standards listed in the test (paras 6-5 through 6-10) are based on the

assumption that all MWO'S applicable to the equipment have been performed. A listing of current MWO'S will be found in DA Pamphlet 310-7.

6-5. Tests

Since each test is dependent on the preceding one for certain operating procedures and test equipment calibrations, the tests should be conducted in sequence, starting with the physi-

cal tests and inspections (para 6-6). The instructions in the heading of each test are to be complied with before beginning the test procedures. The body of the test is divided into steps, each of which must be completed before proceeding to the next step. Each step is to be performed by completing the procedure in each column, in turn, starting with the *Control settings, Test equipment* column, and proceeding towards the right-hand side of the chart.

6-6. Physical Tests and Inspection

- a. *Test Equipment and Materials.* None.
- b. *Test Connections and Conditions.* Remove the multimeter set cover.
- c. *Procedure.*

Step No.	Control saettings		Test procedure	Performance standard
	Test equipment	Equipment under test		
1	N/A	N/A	<p>a. Inspect all jacks for looseness or damage. Insert a test lead prod into each jack to test the condition of the contact spring.</p> <p>b. Inspect the case and the front panel for damage or missing parts and inspect the condition of the finish.</p>	<p>a. No looseness or damage should be evident.</p> <p>b. No damage or missing parts should be evident. No surface intended to be painted should show bare metal. All lettering should be legible.</p>
2	N/A	N/A	<p>a. Operate the OHMS ZERO ADJ control from completely clockwise to completely counterclockwise.</p> <p>b. Operate the FUNCTION switch and range switch to each position indicated on the front panel.</p>	<p>a. Control rotates freely without binding. Knob is tight on the shaft.</p> <p>b. Switch action is positive with no looseness or binding. Knobs are properly indexed and tight on the shaft.</p>
3	N/A	N/A	<p>a. Remove the battery compartment cover and inspect the interior for damage, missing parts, or corroded battery contacts.</p> <p>b. Replace the battery compartment cover before proceeding with the tests.</p>	<p>a. No damaged or missing parts should be evident. There should be no signs of corrosion on the battery contacts or elsewhere in the compartment.</p> <p>b. N/A.</p>

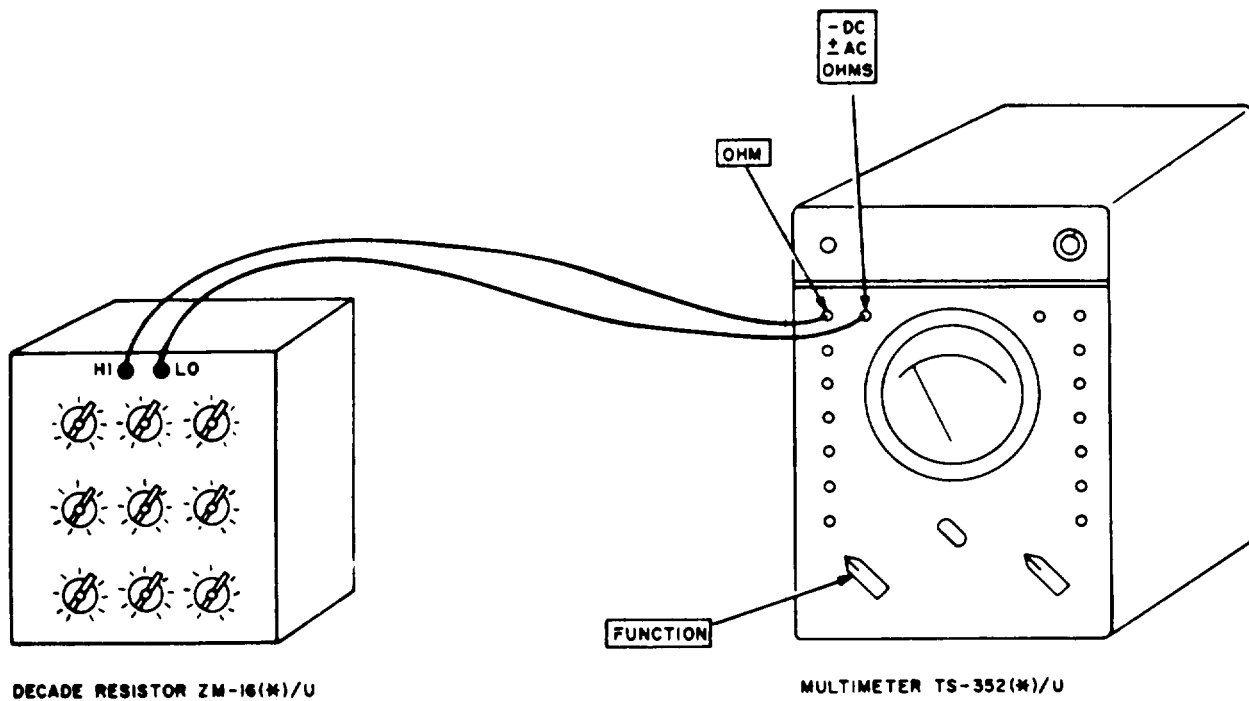

TM5527 - C3 - 3

Figure 6-1. Ohmmeter function test.

6-7. Ohmmeter Function Test

a. *Test Equipment and Materials.*

Decade Resistor ZM-16(☆)/U

b. *Test Connection and Conditions.* Make no connections until instructed to do so in the test procedure.

c. *Procedure.*

Step No.	Control settings		Test procedure	Performance standard
	Test equipment	Equipment under test		
1	ZM-16(☆)/U: X1 switch: 5. X10 switch: 2. All other switches: 0.	FUNCTION switch: OHMS. Range switch: RX1.	a. Install batteries and test leads into multimeter. b. Short the test leads together, and zero the meter. c. Connect the equipment as shown in figure 6-1, and note the indication on the meter.	a. None. b. None. c. Meter indicates $5 \pm 3/4$ of one dc scale division on the 0-10 volt scale.
2	ZM-16(☆)/U: X10 switch: 6. X100 switch: 2. All other switches: 0.	Range switch: RX10.	Same as step 1.	Same as step 1 c.
3	ZM-16(☆)/U: X100 switch: 6. X1000 switch: 2. All other switches: 0.	Range switch: RX100.	Same as step 1.	Same as step 1 c.
4	ZM-16(☆)/U: X1000 switch: 6. X10000 switch: 2. All other switches: 0.	Range switch: X1000.	Same as step 1.	Same as step 1 c.
s	ZM-16(☆)/U: X10000 switch: 6. X100000 switch : 2. All other switches: 0.	Range switch: RX10000.	Same as step 1.	Same as step 1 c.

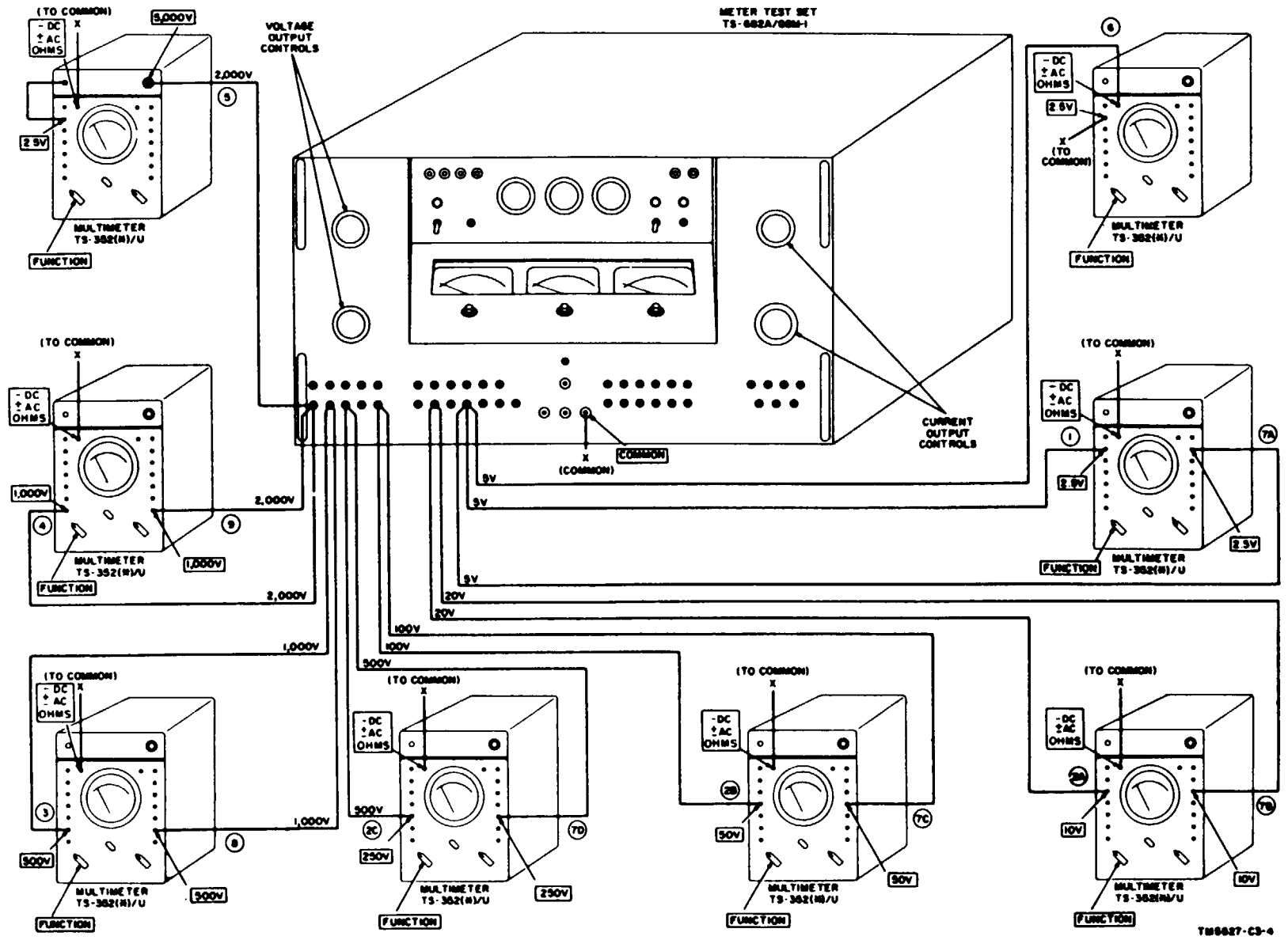

Figure 6-2. Dc voltage function test connection.

6-8. Dc Voltage Function Test

TM 11-6625-366-15

a. Test Equipment and Materials.
Meter Test Set TS-682A/GSM-1
or
Meter Test Set TS-682/GSM-1.

b. Test Connections and Conditions. Connect a test lead between the common terminal post on the meter test set (fig. 6-2) and the -DC \pm AC jack on the multimeter. Do not make any other connection until instructed to do so in the test procedure.

Note. Jack panel markings on the TS-682A/GSM-1 of 5V and 500V correspond to the jack markings on the TS-682/GSM-1 of 4V and 400V.

c. Procedure.

Step No.	Control settings		Test procedure	Performance standard
	Test equipment	Equipment under test		
1	<p>TS-682A/GSM-1:</p> <p><i>Note.</i> For TS-682/GSM-1, use the corresponding control settings shown in parentheses.</p> <p>AC LINE switch: OFF.</p> <p>BATTERY switch: OFF.</p> <p>Output controls: maximum counterclockwise.</p> <p>Right-hand selector switch: AC AND DC (may be in any position).</p> <p>Center selector switch: DC VOLTS AND MA. (ACV-DCV).</p> <p>Left-hand selector switch: .1 TO 500V. (100 MV DC TO 400 VDC).</p>	FUNCTION switch: DIRECT.	<p>a. Connect the equipment as shown in figure 6-2, step 1.</p> <p>b. Operate the AC LINE switch on the meter test set to ON.</p> <p>c. Adjust the voltage output controls on the meter test set until the multimeter indicates full-scale deflection on the dc scale.</p> <p>d. Press the BUZZER switch on the meter test set for approximately 2 seconds; note the indication on center meter (right hand meter if TS-682/GSM-1 is used) of the meter test set.</p> <p><i>Note.</i> TS-682/GSM-1 does not have a buzzer. Tap the face of the meter lightly with the fingers to overcome friction of the meter movement.</p> <p>e. Operate the voltage output controls maximum counterclockwise.</p>	<p>a. N/A.</p> <p>b. None.</p> <p>c. None.</p> <p>d. Indication on the meter test set should be 2.5 ± 0.075 volt</p> <p>e. N/A.</p>
2	Same as step 1.	Same as step 1.	<p>Repeat test procedures c, d, and e of step 1, for each of the following equipment connections (fig. 6-2):</p> <p>a. Step 2A (10 volts).</p> <p>b. Step 2B (50 volts).</p> <p>c. Step 2C (250 volts).</p> <p><i>Warning:</i> HIGH VOLTAGE! Turn the voltage output controls on the meter test set fully counterclockwise before making any changes to the connections.</p>	<p>Indication on the meter test set should be:</p> <p>a. 10 ± 0.3 volt.</p> <p>b. 50 ± 1.5 volt</p> <p>c. 250 ± 7.5 volts</p>
3	<p>TS-682(*)/GSM-1:</p> <p>Left-hand selector switch: 1000 VDC.</p>	Same as step 1.	<p>a. Connect the equipment as shown in figure 6-2, step 3.</p> <p>b. Repeat test procedures c, d, and e of step 1.</p>	<p>a. N/A.</p> <p>b. Indication on the meter test set should be 500 ± 15 volts.</p>
4	<p>TS-682(*)/GSM-1:</p> <p>Left-hand selector switch: 2000 VDC.</p>	Same as step 1.	<p>a. Connect the equipment as shown in figure 6-2, step 4.</p> <p>b. Repeat test procedures c, d, and e of step 1.</p>	<p>a. N/A.</p> <p>b. Indication on the meter test set should be $1,000 \pm 40$ volts</p>
5	Same as step 4.	Same as step 1.	<p>a. Connect the equipment as shown in figure 6-2, step 5.</p> <p>b. Adjust the dc voltage output control until the center meter (right-hand meter on TS-682/GSM-1) of the meter set indicates 2,000 volts.</p> <p>c. Press the BUZZER switch and readjust the output controls if necessary.</p> <p><i>Note.</i> TS-682/GSM-1 does not have a buzzer. Tap the face of the meter lightly with the fingers to overcome friction of the meter movement.</p> <p>d. Note the indication on the multimeter.</p> <p>e. Operate the voltage output controls counterclockwise.</p>	<p>a. N/A.</p> <p>b. None.</p> <p>c. None.</p> <p>d. Indication on the multimeter should be 2,000 volts ± 120 volts.</p> <p>e. N/A.</p>
6	<p>TS-682A/GSM-1:</p> <p><i>Note.</i> For TS-682/GSM-1, use the corresponding control setting shown in parentheses.</p> <p>Left-hand selector switch: .1 TO 500V. (100 MV DC TO 400 VDC).</p>	FUNCTION switch: 20,000 Ω /VDC REV.	<p>a. Connect the equipment as shown in figure 6-2, step 6.</p> <p>b. Repeat test procedures c, d, and e of step 1.</p>	<p>a. N/A.</p> <p>b. Indication on meter test set should be 2.5 ± 0.075 volts.</p>
7	Same as step 6.	FUNCTION switch: 1000 Ω /VDC.	<p>Repeat test procedures c, d, and e of step 1 for each of the following equipment connections:</p> <p>a. Step 7A (2.5 volts).</p> <p>b. Step 7B (10 volts).</p> <p>c. Step 7C (50 volts).</p> <p>d. Step 7D (250 volts).</p> <p><i>Warning:</i> HIGH VOLTAGE! Turn the voltage output controls on the meter test set fully counterclockwise before making any changes to the connections.</p>	<p>Indication on meter test set should be:</p> <p>a. 2.5 ± 0.075 volt.</p> <p>b. 10 ± 0.3 volt.</p> <p>c. 50 ± 1.5 volts.</p> <p>d. 250 ± 7.5 volts.</p>
8	<p>TS-682(*)/GSM-1:</p> <p>Left-hand selector switch: 1000 VDC.</p>	Same as step 7.	<p>a. Connect the equipment as shown in figure 6-2, step 8.</p> <p>b. Repeat test procedures c, d, and e of step 1.</p>	<p>a. N/A.</p> <p>b. Indication on the meter test set should be 500 ± 15 volts.</p>
9	<p>TS-682(*)/GSM-1:</p> <p>Left-hand selector switch: 2000 VDC.</p>	Same as step 7.	<p>a. Connect the equipment as shown in figure 6-2, step 9.</p> <p>b. Repeat test procedures c, d, and e of step 1.</p>	<p>a. N/A.</p> <p>b. Indication on the meter test set should be $1,000 \pm 30$ volts.</p>

6-9. Ac Voltage Function Test

- a. *Test Equipment and Materials.*
Meter Test Set TS-682A/GSM-1

Meter Test Set TS-682/GSM-1.

- b. *Test Connections and Conditions.* Make no connections until instructed to do so in the test procedure.
- c. *Procedure.*

Step No.	Control settings		Test procedure	Performance standard
	Test equipment	Equipment under test		
1	<p><i>TS-682A/GSM-1:</i></p> <p>Note. For TS-682/GSM-1, use corresponding control settings shown in parentheses.</p> <p>AC LINE switch: ON.</p> <p>Output controls: maximum counterclockwise.</p> <p>Right-hand selector switch: AC AND DC VOLTS. (May be in any position.)</p> <p>Center selector switch: AC VOLTS. (ACV-DCV) .</p> <p>Left-hand selector switch: ALL OTHER AC AND DC SCALES (ACV) .</p>	<p>FUNCTION switch : AC VOLTS.</p>	<p>a. Connect the equipment as shown in figure 6-3, step 1.</p> <p>b. Adjust the voltage output controls on the meter test set until the multimeter indicates full-scale deflection on the ac scale.</p> <p>c. Note the indication on the left-hand meter of the meter test set.</p> <p>Warning: HIGH VOLTAGE! Turn the voltage output controls on the meter test set fully counterclockwise before making any changes to the connections.</p> <p>Note. If the dc voltage function test (para 6-8, steps 7, 8, and 9) was performed, it is not necessary to perform step 2 of this test.</p>	<p>a. N/A.</p> <p>b. None.</p> <p>c. Indication on the meter test set should be 2.5 ± 0.1 volt .</p>
2			<p>Repeat test procedures b and c of step 1 for the following equipment connection:</p> <p>a. Step 2A (10 volts).</p> <p>b. Step 2B (50 volts) .</p> <p>c. Step 2C (250 volts).</p> <p>d. Step) 2D (500 volts) .</p> <p>e. Step 2E (1,000 volts).</p>	<p>Indication on the meter test set should be:</p> <p>a. 10 ± 0.4 volt.</p> <p>b. 50 ± 2 volts. ₁</p> <p>c. 250 ± 10 volts.</p> <p>d. 500 ± 20 volts.</p> <p>e. $1,000 \pm 50$ volts.</p>

Change 2

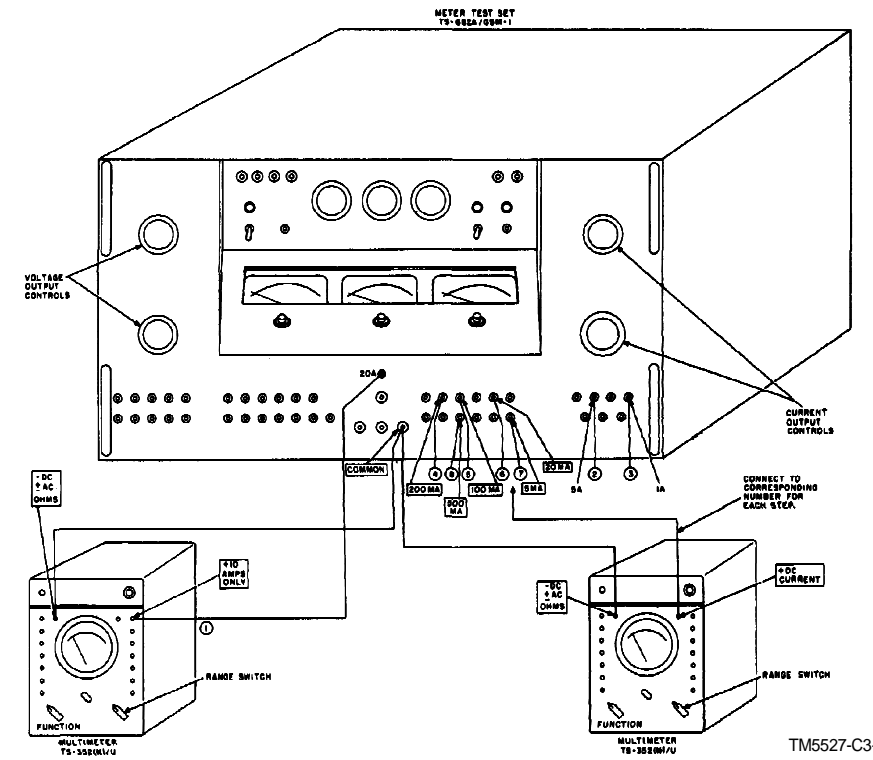

Figure 6-4. Dc ammeter function test connections.

TM5527-C3-6

6-10. Dc Ammeter Function Test

C 1, TM 11-6625-366-15

a. Test Equipment and materials.

Meter Test Set TS-682A/GSM-1

or

Meter Test Set TS-682/GSM-1.

Power Supply PP-1097A/G or PP-1104A/G, or wet Battery BA-46.

b. Test Connections and Conditions. Connect the power supply to the binding posts inside the door on the rear panel of the meter test set. Make no other connections until instructed to do so in the test procedure.

c. Procedure.

Step No.	Control settings		Test procedure	Performance standard
	Test equipment	Equipment under test		
1	<p>TS-682A/GSM-1:</p> <p>Note: For TS-682/GSM-1, use corresponding control settings shown in parentheses.</p> <p>AC LINE switch: OFF.</p> <p>BATTERY switch: OFF.</p> <p>Output controls: Maximum counterclockwise.</p> <p>Right-hand selector switch: 20 A.</p> <p>Center selector switch: DC AMPERES. (AC & DC CUR).</p> <p>Left-hand selector switch: ALL OTHER AC AND DC SCALE. (May be in any position.)</p>	<p>FUNCTION switch: DC CURRENT</p> <p>Range switch: 2.5 AMP.</p>	<p>a. Connect the equipment as shown in figure 6-4, step 1.</p> <p>b. Operate the BATTERY switch to ON.</p> <p>c. Adjust the current output controls on the meter test set until the multimeter indicate full-scale deflection on the dc scale.</p> <p>d. Press the BUZZER switch on the meter test set for approximately 2 seconds; note the indication on the center meter (right-hand meter on TS-682/GSM-1) of the meter test set.</p> <p>Note: TS-682/GSM-1 does not have a buzzer. Tap the face of the meter lightly with the fingers to overcome friction of the meter movement.</p> <p>Warning: HIGH VOLTAGE! Turn the current output controls on the meter set fully counterclockwise before making any change to the connections.</p>	<p>a. N/A.</p> <p>b. N/A.</p> <p>c. None.</p> <p>d. Indication on the meter test set should be 10 ± 0.3 amp.</p>
2	<p>TS-682A/GSM-1:</p> <p>Right-hand selector switch: 5A. (4A).</p>	Same as step 1.	<p>a. Connect the equipment as shown in figure 6-4, step 2.</p> <p>b. Repeat procedures c and d of step 1.</p>	<p>a. N/A.</p> <p>b. Indication on the meter test set should be 2.4 ± 0.075 amp.</p>
3	<p>TS-682A/GSM-1:</p> <p>Right-hand selector switch: 1A. (2A-1A).</p>	Range switch: 500 MA.	<p>a. Connect the equipment as shown in figure 6-4, step 3.</p> <p>b. Repeat test procedures c and d of step 1.</p>	<p>a. N/A.</p> <p>b. Indication on meter test set should be 500 ± 15 ma.</p>
4	<p>TS-682A/GSM-1:</p> <p>Right-hand selector switch: AC AND DC MA AND A (100μ A TO 400 MA).</p> <p>Center selector switch: DC MA AND μA. (AC & DC CUR).</p>	Range switch: 100 MA.	<p>a. Connect the equipment as shown in figure 6-4, step 4.</p> <p>b. Repeat test procedures c and d of step 1.</p>	<p>a. N/A.</p> <p>b. Indication on the meter test set should be 100 ± 3 MA.</p>
5	Same as step 4.	Range switch: 50 MA.	<p>a. Connect the equipment as shown in figure 6-4, step 5.</p> <p>b. Repeat test procedures c and d of step 1.</p>	<p>a. N/A.</p> <p>b. Indication on the meter test set should be 50 ± 1.5 ma.</p>
6	Same as step 4.	Range switch: 10 MA.	<p>a. Connect the equipment as shown in figure 6-4, step 6.</p> <p>b. Repeat test procedures c and d of step 1.</p>	<p>a. N/A.</p> <p>b. Indication on the meter test set should be 10 ± 3 ma.</p>
7	Same as step 4.	Range switch: 2.5 MA.	<p>a. Connect the equipment as shown in figure 6-4, step 7.</p> <p>b. Repeat test procedures c and d of step 1.</p>	<p>a. N/A.</p> <p>b. Indication on the meter test set should be 2.5 ± 0.075 ma.</p>
8	Same as step 4.	Range switch: 250 MICRO A.	<p>a. Connect the equipment as shown in figure 6-4, step 8.</p> <p>b. Repeat test procedures c and d of step 1.</p>	<p>a. N/A.</p> <p>b. Indication on the meter test set should be 250 ± 7.5 μA.</p>

6-11. Test Data Summary

A summary of the test data is shown below.

<i>Test data</i>	<i>Performance standard</i>
1. OHMMETER	
FUNCTION TEST	
a. RX1	5 volts \pm % of a dc scale division for all ranges.
b. RX10	
c. RX100	
d. RX1000	
e. RX10000	
<hr/>	
2. DC VOLTAGE	
FUNCTION TEST	
a. 20,000 Ω /VDC	
DIRECT	
(1) 2.5 V	2.5 \pm 0.1 volt
(2) 10 V	10 \pm 0.4 volt
(3) 50 V	50 \pm 2.0 volts
(4) 250 V	250 \pm 10.0 volts
(5) 500 V	500 \pm 20.0 volts
(6) 1000 V	1000 \pm 40 volts
b. 5000 volt multiplier	2,000 \pm 120 volts
c. 20000 Ω /VDC REV.	2.5 \pm 0.075 volts
d. 1000 Ω /VDC	
(1) 2.5 V	2.5 \pm 0.075 volts

<i>Test data</i>	<i>Performance standard</i>
(2) 10 V	10 \pm 3 volt
(3) 50 V	50 \pm 1.5 volts
(4) 250 V	250 \pm 7.5 volts
(5) 500 V	500 \pm 15 volts
(6) 1000 V	1000 \pm 30 volts

<hr/>	
3. AC VOLTMETER	
FUNCTION TEST	
a. 2.5 V	2.5 \pm 0.1 volts
b. 10 V	10 \pm 0.4 volts
c. 50 V	50 \pm 2 volts
d. 250 V	250 \pm 10 volts
e. 500 V	500 \pm 20 volts
f. 1,000 V	1,000 \pm 50 volts

<hr/>	
4. DC AMMETER	
FUNCTION TEST	
a. 10 A	10 \pm 0.3 amp
b. 2.5 A	2.5 \pm 0.075 amp
c. 500 MA	500 \pm 15 ma
d. 100 MA	100 \pm 3 ma
e. 50 MA	50 \pm 1.5 ma
f. 10 MA	10 \pm 3 ma
g. 2.5 MA	2.5 \pm 0.075 ma
h. 250 μ A	250 \pm 7.5 μ A

CHAPTER 7

DEPOT OVERHAUL STANDARDS

7-1. Applicability of Depot Overhaul Standards

The tests outlined in this chapter are designed to measure the performance capability of repaired equipment. Equipment that is to be returned to dock should meet the standards given in these tests.

7-2. Applicable References

a. Repair Standards. Applicable procedures of the depots performing these tests and the general standards for repaired electronic equipment given in TB SIG 355-1, TB SIG 355-2, and TB SIG 355-3 form part of the requirements for testing this equipment.

b. Modification Work Orders. Perform all modification work orders applicable to this

equipment before making the tests specified. DA Pam 310-7 lists all available MWO's.

7-3. Test Facilities Required

The following items are required for depot testing:

Nomenclature	Technical manual	Common name
Meter Test Set TS-682A/GSM-1	TM 11-6425-277-14	Test set
Decade Resistor ZM-16(☆)/U	TM 11-5102	Decade resistor

7-4. Testing of Multimeter TS-352B/U

To perform the Depot Overhaul Standards on Multimeter TS-352B/U, perform the tests described in paragraph 6-7 through 6-10.

SHIPMENT AND LIMITED STORAGE AND DEMOLITION TO PREVENT ENEMY USE

8-1. Repacking for Shipment and Limited Storage

a. The original packing materials may be used to repack the multimeter. Repack the equipment as shown in figure 2-1.

Note. Be sure that the batteries are not left in the battery compartment.

b. Pack the multimeter securely to prevent damage during transit or limited storage. Use sufficient wadding. Protect the equipment from rain and dew.

8-2. Authority for Demolition

The demolition procedure given in paragraph 8-3 will be used to prevent the enemy from using or salvaging this equipment. Demolition of the equipment will be accomplished only upon the order of the commander.

8-3. Methods of Destruction

The tactical situation and time available will determine the method to be used when destruction of equipment is ordered. In most cases, it is preferable to demolish completely some portions of the equipment rather than partially destroy all the equipment components.

a. Smash. Smash the cabinet, meters, and controls. Smash the internal component.

b. Cut. Cut the wiring of the power supply.

Warning: Be extremely careful with explosives and incendiary devices. Use these items only when the need is urgent.

c. Burn. Burn the technical manuals first. Burn as much of the equipment as is flammable.

d. Dispose. Bury or scatter destroyed parts.

COLOR CODE MARKING FOR MILITARY STANDARD RESISTORS

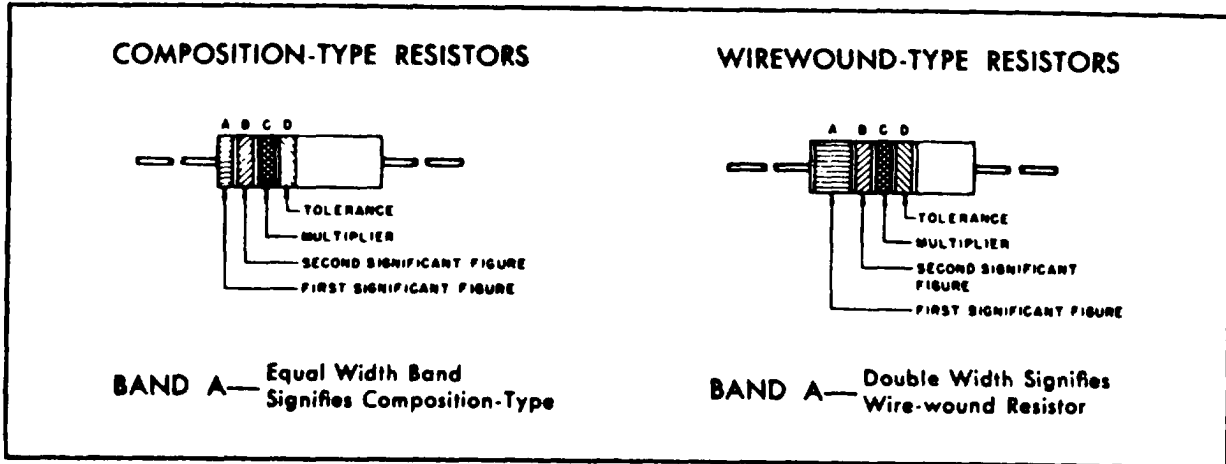

COLOR CODE TABLE

BAND A		BAND B		BAND C		BAND D*	
COLOR	FIRST SIGNIFICANT FIGURE	COLOR	SECOND SIGNIFICANT FIGURE	COLOR	MULTIPLIER	COLOR	RESISTANCE TOLERANCE (PERCENT)
BLACK	0	BLACK	0	BLACK	1		
BROWN	1	BROWN	1	BROWN	10		
RED	2	RED	2	RED	100		
ORANGE	3	ORANGE	3	ORANGE	1,000		
YELLOW	4	YELLOW	4	YELLOW	10,000	SILVER	± 10
GREEN	5	GREEN	5	GREEN	100,000	GOLD	± 5
BLUE	6	BLUE	6	BLUE	1,000,000		
PURPLE (VIOLET)	7	PURPLE (VIOLET)	7				
GRAY	8	GRAY	8	SILVER	0.01		
WHITE	9	WHITE	9	GOLD	0.1		

EXAMPLES OF COLOR CODING

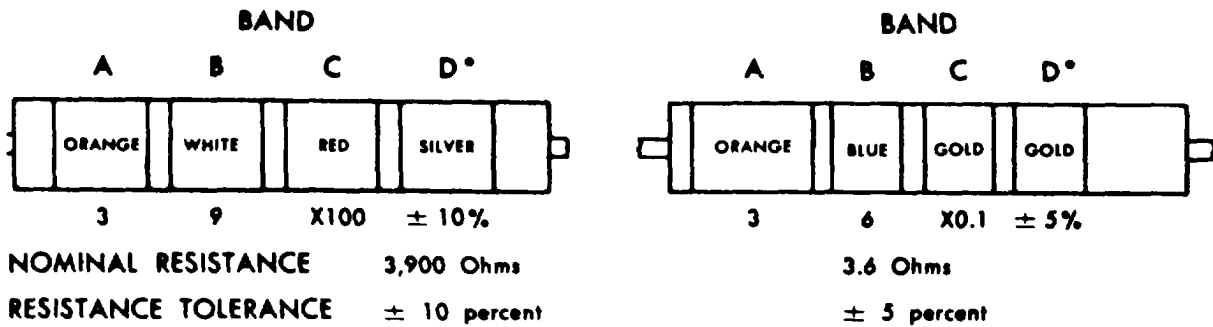

*If Band D is omitted, the resistor tolerance is ± 20%, and the resistor is not Mil-Std.

STD-R2

Figure 8-1. MIL-STD resistor color code markings.

COLOR CODE MARKING FOR MILITARY STANDARD CAPACITORS

GROUP I Capacitors, Fixed, Various-Dielectrics, Styles CM, CN, CY, and CB

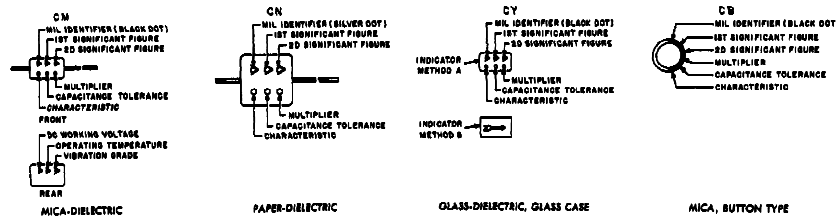

GROUP II Capacitors, Fixed Ceramic-Dielectric (General Purpose) Style CK

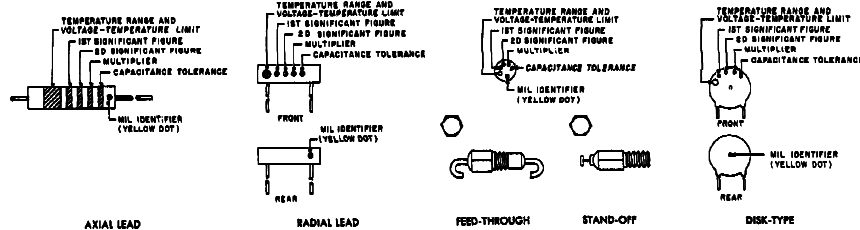

GROUP III Capacitors, Fixed, Ceramic-Dielectric (Temperature Compensating) Style CC

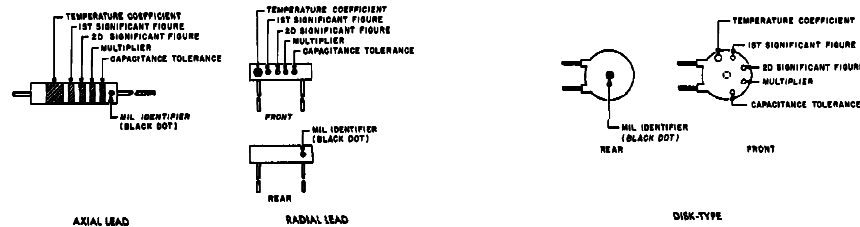

COLOR CODE TABLES

TABLE I - For use with Group I, Styles CM, CN, CY and CB

COLOR	MIL ID	1st SIG FIG	2nd SIG FIG	MULTIPLIER ¹	CAPACITANCE TOLERANCE				CHARACTERISTIC ²				DC WORKING VOLTAGE		OPERATING TEMP. RANGE		VIBRATION GRADE	
					CM	CN	CY	CB	CM	CN	CY	CB	CM	CN	CM	CN		
BLACK	CM, CY, CB	0	0	1												-55° to +70°C	10-88 cps	
BROWN		1	1	10						B	E					-55° to +125°C		
RED		2	2	100	± 5%		± 5%	± 5%		C	C							
ORANGE		3	3	1,000		± 30%						D		300				
YELLOW		4	4	10,000						E						-55° to +125°C	10-1,000 cps	
GREEN		5	5		± 5%					F				500				
BLUE		6	6													-55° to +125°C		
PURPLE (Violet)		7	7															
GREY		8	8															
WHITE		9	9	0.1														
GOLD																		
SILVER	CN				± 10%	± 10%	± 10%	± 10%										

TABLE II - For use with Group II, General Purpose, Style CK

COLOR	TEMP. RANGE AND VOLTAGE - TEMP. LIMITS ³	1st SIG FIG	2nd SIG FIG	MULTIPLIER ¹	CAPACITANCE TOLERANCE	MIL ID
BLACK	0 0	0	0	1	± 50%	
BROWN	AW	1	1	10	± 10%	
RED	AX	2	2	100		
ORANGE	BX	3	3	1,000		
YELLOW	AY	4	4	10,000		CK
GREEN	CX	5	5			
BLUE	AX	6	6			
PURPLE (Violet)		7	7			
GREY		8	8			
WHITE		9	9			
GOLD						
SILVER						

TABLE III - For use with Group III, Temperature Compensating, Style CC

COLOR	TEMPERATURE COEFFICIENT ⁴	1st SIG FIG	2nd SIG FIG	MULTIPLIER ¹	CAPACITANCE TOLERANCE		MIL ID
					Capacitance over 10µuf	Capacitance 10µuf or less	
BLACK	0	0	0	1	± 50%	± 50%	CC
BROWN	-20	1	1	10	± 1%		
RED	-80	2	2	100	± 5%	± 0.15µuf	
ORANGE	-180	3	3	1,000			
YELLOW	-320	4	4				
GREEN	-520	5	5		± 5%	± 0.5µuf	
BLUE	-720	6	6				
PURPLE (Violet)		7	7				
GREY		8	8	0.01			
WHITE		9	9	0.1	± 10%		
GOLD	+100					± 1.0µuf	
SILVER							

- The multiplier is the number by which the two significant (SIG) figures are multiplied to obtain the capacitance in µuf.
- Letters indicate the Characteristics designated in applicable specifications: MIL-C-5, MIL-C-91, MIL-C-11272, and MIL-C-10950 respectively.
- Letters indicate the temperature range and voltage-temperature limits designated in MIL-C-11013.
- Temperature coefficient in parts per million per degree centigrade.

Figure 8-2. MIL-STD capacitor color code markings.

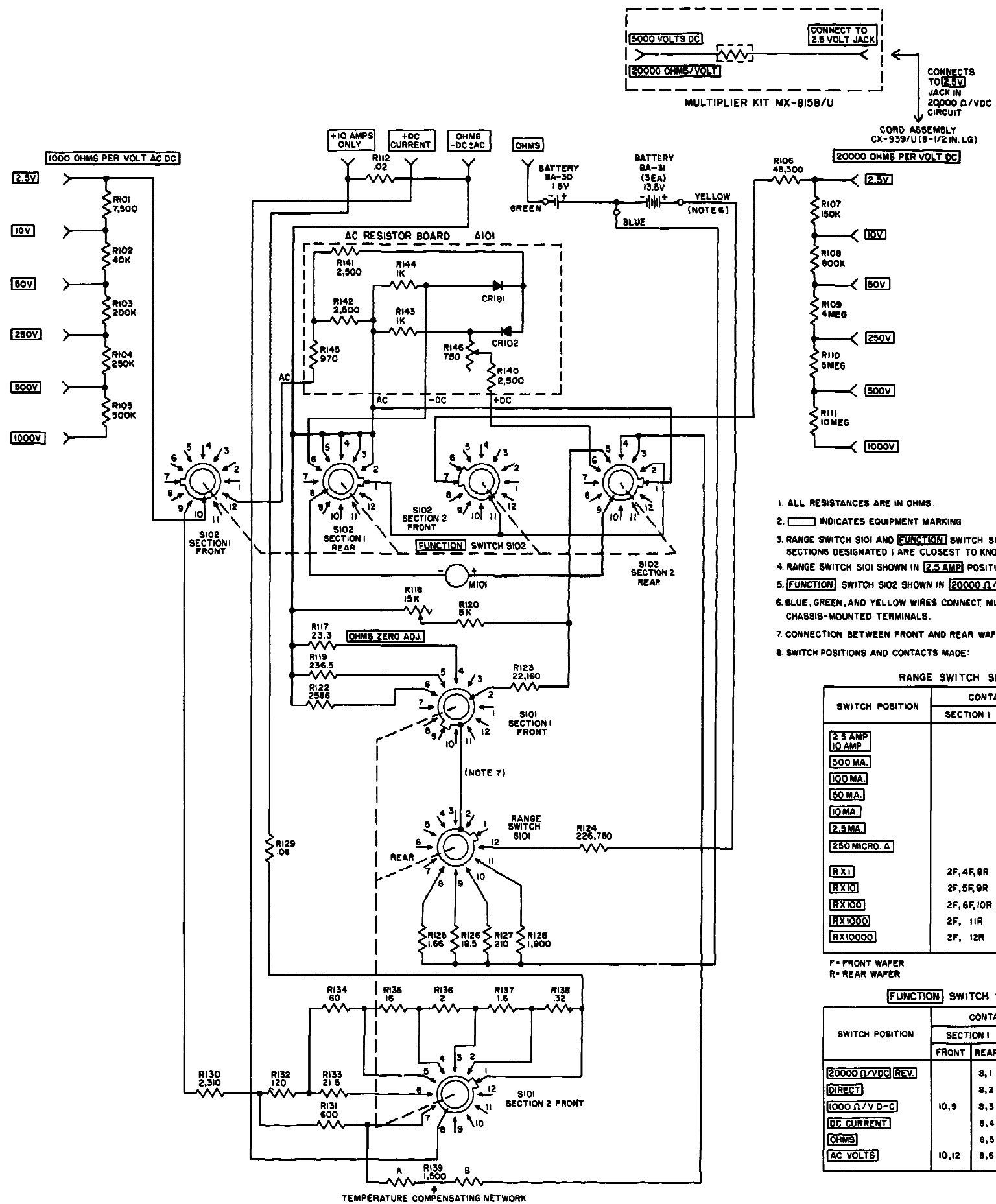

- NOTES:
1. ALL RESISTANCES ARE IN OHMS.
 2. INDICATES EQUIPMENT MARKING.
 3. RANGE SWITCH S101 AND FUNCTION SWITCH S102 ARE VIEWED FROM END FARTHEST FROM KNOB. SECTIONS DESIGNATED 1 ARE CLOSEST TO KNOB.
 4. RANGE SWITCH S101 SHOWN IN 2.5 AMP POSITION.
 5. FUNCTION SWITCH S102 SHOWN IN 20000 Ω/V DC REV. POSITION.
 6. BLUE, GREEN, AND YELLOW WIRES CONNECT MULTIMETER TO BATTERIES THRU INSULATED CHASSIS-MOUNTED TERMINALS.
 7. CONNECTION BETWEEN FRONT AND REAR WAFERS OF SECTION 1 OF SWITCH S101 IS A RIVET.
 8. SWITCH POSITIONS AND CONTACTS MADE:

RANGE SWITCH S101

SWITCH POSITION	CONTACTS MADE	
	SECTION 1	SECTION 2
2.5 AMP		* 8,1
10 AMP		8,2
500 MA.		8,3
100 MA.		8,4
50 MA.		8,5
10 MA.		8,6
2.5 MA.		8,7
250 MICRO. A.		
RX 1	2F, 4F, 8R	
RX 10	2F, 5F, 9R	
RX 100	2F, 6F, 10R	
RX 1000	2F, 11R	
RX 10000	2F, 12R	

F = FRONT WAFER
R = REAR WAFER

FUNCTION SWITCH S102

SWITCH POSITION	CONTACTS MADE			
	SECTION 1		SECTION 2	
	FRONT	REAR	FRONT	REAR
20000 Ω/V DC REV.		8,1	11,7	9,1
DIRECT		8,2	11,7	9,2
1000 Ω/V DC	10,9		8,3	9,3
DC CURRENT		8,4		9,4
OHMS		8,5		9,5
AC VOLTS	10,12	8,6		9,6

Figure 8-3. Multimeter TS-352B/U, schematic diagram.

APPENDIX A REFERENCES

DA Pam 310-4	Index of Technical Manuals, Technical Bulletins, Supply Manuals, (Types 7, 8, and 9), Supply Bulletins and Lubrication Orders.
DA Pam 310-7	US Army Equipment Index of Modification Work Orders.
SB 11-6	FSC Class 6135; Dry Battery Supply Data.
TB 43-0118	Field Instructions for Painting and Preserving Electronics Command Equipment Including Camouflage Pattern Painting of Electrical Equipment Shelters.
TB SIG 355-1	Depot Inspection Standards for Repaired Signal Equipment.
TB SIG 355-2	Depot Inspection Standards for Refinishing Repaired Signal Equipment.
TB SIG 355-3	Depot Inspection Standards for Moisture and Fungus Resistant Treatment.
TM 11-5102	Resistors, Decade ZM-16/U (NS 6625-00-669-0266), ZM-16A/U and ZM-16B/U.
TM 11-5126	Power Supplies PP-1104A/G and PP-1104B/G.
TM 11-6625-277-14	Operator's, Organizational, Direct Support, and General Support Maintenance Manual: Meter Test Sets TS-682/GSM-1 and TS-682A/GSM-1 (NSN 6625-00-669-0747).
TM 38-750	The Army Maintenance Management System (TAMMS).
TM 750-244-2	Procedures for Destruction of Electronics Materiel to Prevent Enemy Use (Electronics Command).

APPENDIX C

MAINTENANCE ALLOCATION

Section I. INTRODUCTION

C-1. General

This appendix provides a summary of the maintenance operations covered in the equipment literature for multimeter TS-352B/U. It authorizes categories of maintenance for specific maintenance functions on repairable items and components and the tools and equipment required to perform each function. This appendix may be used as an aid in planning maintenance operations.

C-2. Explanation of Format for Maintenance Allocation Chart

a. Group Number. Not used.

b. Component Assembly Nomenclature. This column lists the item names of component units, assemblies, subassemblies, and modules on which maintenance is authorized.

c. Maintenance Function. This column indicates the maintenance category at which performance of the specific maintenance function is authorized. Authorization to perform a function at any category also includes authorization to perform that function at higher categories. The codes used represent the various maintenance categories as follows:

<i>Code</i>	<i>Maintenance Category</i>
C	Operator/Crew
O	Organizational Maintenance
F	Direct Support Maintenance
H	General Support Maintenance
D	Depot Maintenance

d. Tools and Equipment. The numbers appearing in this column refer to specific tools and equipment which are identified by these numbers in section III.

e. Remarks. Self explanatory.

C-3. Explanation of Format for Tool and Test Equipment Requirements

The columns in the tool and test equipment requirements chart are as follows:

a. Tools and Equipment. The numbers in this column coincide with the numbers used in the tools and equipment column of the MAC. The numbers indicate the applicable tool for the maintenance function.

b. Maintenance Category. The codes in this column indicate the maintenance category normally allocated the facility.

c. Nomenclature. This column lists tools, test and maintenance equipment required to perform the maintenance functions.

d. Federal Stock Number. This column lists the Federal stock number.

e. Tool Number. Not used.

SECTION II. MAINTENANCE ALLOCATION CHART

MAINTENANCE ALLOCATION CHART														
GROUP NUMBER	COMPONENT ASSEMBLY NOMENCLATURE	MAINTENANCE FUNCTIONS									TOOLS AND EQUIPMENT	REMARKS		
		INSPECT	TEST	SERVICE	ADJUST	ALIGN	CALIBRATE	INSTALL	REPLACE	REPAIR			OVERHAUL	REBUILD
	MULTIMETER TS-352B/U	C	H	C		H							1,2,3	Replace batteries & knobs
	MULTIMETER ME-9H/U								O	H			1 5 4	
									O	H	D		1,2,3,4	
													5 4	

SECTION III. TOOL AND TEST EQUIPMENTS REQUIREMENTS

TOOL AND TEST EQUIPMENT REQUIREMENTS				
TOOLS AND EQUIPMENT	MAINTENANCE CATEGORY	NOMENCLATURE	FEDERAL STOCK NUMBER	TOOL NUMBER
		TS-352B/U (continued)		
1	H,D	METER TEST SET TS-682/OSM-1	6625-669-0747	
2	H,D	MULTIMETER TS-352B/U	6625-553-0142	
3	H,D	RESISTOR, DECADE EM-16/U	6625-669-0866	
4	H,D	TOOL KIT, ELECTRONIC EQUIPMENT TK-100G	5180-605-0079	
5	O	TOOLS AND TEST EQUIPMENT NORMALLY SUPPLIED TO THE REPAIRMAN USER BECAUSE OF HIS ASSIGNED MISSION		

INDEX

	Paragraph	Page
Additional equipment required -----	1-8	1-2
Alignment procedure -----	5-6	5-4
Multimeter TS-352B/U, exploded view, fig. 5-2.		
Alternating current:		
Voltage function test -----	6-9	6-9
Test connections, fig. 6-3.		
Voltage test -----	7-6	
Voltmeter circuit -----	4-4	4-4
Simplified schematic diagram, fig. 4-7.		
Applicability, depot overhaul standards -----	7-1	7-1
Applicable references -----	7-2	7-1
Authority, demolition -----	8-2	8-1
Battery installation -----	2-3	2-1
Battery compartment, batteries in position, fig. 2-2.		
Block diagram -----	4-1	4-1
Multimeter, fig. 4-4.		
Checking unpacked equipment -----	2-2	2-1
Cleaning -----	3-7	3-3
Controls, meter, and connectors, fig.2-3 -----	2-5	2-4
Damage from improper settings -----	2-4	2-4
Description, Multimeter TS-352B/U, fig. 1-1 -----	1-7	1-2
Differences, models -----	1-9	
Direct current:		
Ammeter function test -----	6-10	
Test connections, fig.6-4.		
Circuit -----	4-6	4-7
Simplified schematic diagram, fig. 4-9.		
Current test -----	7-7	
Measurements -----	2-9	2-7
Ohms test -----	7-8	
Voltage function test -----	6-8	
Test connections, fig. 6-2.		
Voltage test -----	7-5	
Voltmeter circuit (1,000 ohms per volt) -----	4-2	4-1
Simplified schematic diagram, fig. 4-5.		
Voltmeter circuit (20,000 ohms per volt) -----	4-3	4-2
Simplified schematic diagram, fig. 4-6.		
Schematic diagram, Multimeter TS-352B/U, fig. 6-5.		
Forms and records -----	1-3	1-1
General:		
Alignment -----	5-5	5-4
Instructions -----	5-1	5-1
Testing -----	6-1	6-1
Test requirements -----	7-4	7-1

	Paragraph	Page
Troubleshooting information - - - - -	3-9	3-9
Index, equipment publications - - - - -	1-2	A
List, components - - - - -	1-6	1-2
Localizing and isolating troubles - - - - -	5-3	5-1
Rear view, Multimeter TS-352B/U, fig.5-1.		
Methods, destruction - - - - -	8-3	8-1
Modification work orders - - - - -	6-4	6-1
Ohmmeter circuit - - - - -	4-5	4-5
Simplified schematic diagram, fig. 4-5.		
Ohmmeter function test, fig.6-1 - - - - -	6-7	6-5
Operator's daily preventive maintenance checks and services chart - - - - -	3-4	3-2
Operator's weekly preventive maintenance checks and servicea chart - - - - -	3-5	3-2
Organizational monthly preventive maintenance checks and services chart - - - - -	3-6	3-2
Organization, troubleshooting procedures - - - - -	5-2	5-1
Physical tests and inspection - - - - -	6-6	6-3
Preliminary starting procedure - - - - -	2-6	2-4
Preventive maintenance - - - - -	3-2	3-1
Preventive maintenance checks and service periods - - - - -	3-3	3-1
Purpose and use - - - - -	1-4	1-1
Repacking for shipment and limited storage - - - - -	8-1	8-1
Repairs - - - - -	3-11	3-4
Resistance measurements - - - - -	2-8	2-6
Rustproofing and painting - - - - -	3-8	3-3
Scope - - - - -	1-1	1-1
Multimeter TS-352B/U, fig. 1-1.		
Scope, maintenance - - - - -	3-1	3-1
Technical characteristics - - - - -	1-5	1-1
Test:		
Data summary - - - - -	6-11	6-11
Equipment and materials - - - - -	6-2	6-1
Facilities- - - - -	6-3	6-1
Facilities required - - - - -	7-3	7-1
Tests - - - - -	6-5	6-2
Troubleshooting chart (general support maintenance) - - - - -	5-4	5-2
Troubleshooting chart (operator's and organizational maintenance) - - - - -	3-10	3-4
Unpacking - - - - -	2-1	2-1
Packaging diagram, fig. 2-1.		
Voltage measurements - - - - -	2-7	2-4

By Order of the Secretary of the Army:

HAROLD K. JOHNSON,
General, United States Army,
Chief of Staff.

Official :

KENNETH G. WICKHAM
Major *General, United States Army,*
The Adjutant General.

Distribution:

ACTIVE ARMY :

CNGB (1)
CC-E (7)
Dir of Trans (1)
CofEngrs (1)
TSG (1)
CofSptS (1)
USAARENBD (2)
USAIB (6)
USA Arty Bd (2)
USACDCEA (1)
USACDCCBRA (1)
USACDCCEA (1)
USACDCCEA (Ft Huachuca) (1)
USACDCOA (1)
USACDCQMA (1)
USACDCTA (1)
USACDCADA (1)
USACDCARMA (1)
USACDCAVNA (1)
USACDCARTYA (1)
USACDCSWA (1)
USCONARC (6)
USAMC (6)
USASA (2)
USAMICOM (4)
USASTRATCOM (4)
USAESC (70)
USACDCEC (10)
ARADCOM (6)
ARADCOM Rqn (2)
OS Maj Cored (4) ● xcept
USARJ (6)
USARYIS (6)
LOGCOMD (2)
MDW (1)
Armies (2)
Corps (2)
USAC (S)
Div (2)
Div Arty (2)
Bde (2)
607th USASA Gp (6)
608th USASA Gp (6)
318th USASA Bn (6)
319th USASA Bn (6)
75th USASA Co (6)
1st USASA Fld Sta (6)
2nd USASA Fld Sta (6)
3rd USASA Fld Sta (5)
4th USASA Fld Sta (6)
6th USASA Fld Sta (6)
6th USASA Fld Sta (6)
8th USASA Fld Sta (6)

9th USASA Fld Sta (6)
12th USASA Fld Sta (5)
13th USASA Fld Sta (5)
14th USASA Fld Sta (6)
16th USASA Fld Sta (6)
Instl (2) except
Ft Hancock (4)
Ft Gordon (10)
Ft Huachuca (10)
Ft Carson (26)
Ft Knox (12)
WSMR (6)
Army Dep (2) except
LBAD (14)
SAAD (s0)
TOAD (14)
LEAD (7)
SHAD (8)
NAAD (6)
SVAD (6)
CHAD (8)
ATAD (10)
ERAD (6)
PUAD (6)
UMAD (6)
SCAD (6)
Gen Dep (2)
Sig See, Gen DeP (6)
Sig Dep (12)
USMA (2)
Svc Colleges (2)
USASCS (20)
USASESCS (6)
USAADS (2)
USAAMS (2)
USAARMS (2)
USAIS (2)
USAES (2)
MFSS (2)
USACMLCS (2)
USAOC&S (2)
USATC Armor (2)
USATC Engr (2)
USATC Inf (2)
USASTC (2)
WRAMC (1)
Army Pic Con (2)
USAJFKCENSPWAR (10)
Sig FLDMS (2)
AMS (1)
USAERDAA (2)
USAERDAW (13)
USACRREL (2)

APG (5)	6-365
USAEPG (5)	6-385
USARDL (5)	6-386
Redstone Arsenal (5)	6-405
USARMIS: El Salvador (5)	6-406
Honduras (5)	6-425
Peru (5)	6-246
Paraguay (5)	6-455
Ecuador (5)	6-456
JUSMMAT (2)	6-555
USMTMSA (2)	6-556
ARMISH (2)	6-557
GENMISH (2)	6-565
MAAG: Iran (2)	6-575
Korea (2)	6-576
Thailand (2)	6-577
Pakistan (2)	6-615
Units org under fol TOE:	6-616
(2 copies each)	6-617
1-58	6-619
1-100	6-700
1-101	6-701
1-102	6-702
1-127	7-45
1-128	8-500(RA)
1-137	9-7
1-145	9-9
1-146	9-22
1-147	9-86
1-148	9-117
1-155	9-357
1-156	9-510
1-157	11-17
1-158	11-57
1-165	11-86
1-166	11-87
1-167	11-97
1-307	11-98
5-25	11-105
5-26	11-106
5-48	11-106
5-52	11-117
5-112	11-127
5-115	11-137
5-118	11-147
5-127	11-155
5-137	11-156
5-145	11-157
5-146	11-158
5-155	11-215
5-156	11-216
5-279	11-225
5-348	11-226
5-500(MC)	11-247
6-134	11-302
6-155	11-327
6-166	11-347
6-175	11-357
6-185	11-500 (AA-TK)
6-186	11-587
6-201	11-592
6-215	11-597
6-216	19-55
6-345	19-56
6-346	19-57
6-355	19-500 (OA, OC, PT)

29-1	32-77
29-11	32-78
29-15	32-500
29-16	44-85
29-17	44-86
29-21	44-87
29-25	44-112
29-35	44-235
29-36	44-236
29-37	44-237
29-41	44-535
29-51	44-536
29-55	44-537
29-56	44-568
29-57	55-27
29-75	55-50
29-79	55-89
29-85	55-99
29-86	55-137
29-87	55-167
29-97	55-405
29-105	55-407
29-109	55-417
29-500 (GF)	55-457
30-25	55-458
30-28	55-500 (IF)

NG: State AG (3); units—Same as Active Army except allowance is one copy to each unit.

USAR: None.

For explanation of abbreviations used, see AR 320-50.

